

NCEES
*advancing licensure for
engineers and surveyors*

PE | Electrical and Computer: Power

Reference Handbook
Version 1.1.1

This document may be printed from the NCEES Web site for your personal use, but it may not be copied, reproduced, distributed electronically or in print, or posted online without the express written permission of NCEES. Contact permissions@ncees.org for more information.

Copyright ©2020 by NCEES®. All rights reserved.

All NCEES material is copyrighted under the laws of the United States. No part of this publication may be reproduced, stored in a retrieval system, or transmitted in any form or by any means without the prior written permission of NCEES. Requests for permissions should be addressed in writing to permissions@ncees.org.

Third printing October 2020

PREFACE

About the Handbook

The Principles and Practice of Engineering (PE) Electrical and Computer: Power exam is computer-based, and NCEES will supply all the resource material that you may use during the exam. Reviewing the *PE Electrical and Computer: Power Reference Handbook* before exam day will help you become familiar with the charts, formulas, tables, and other reference information provided. You will not be allowed to bring your personal copy of the *PE Electrical and Computer: Power Reference Handbook* into the exam room. Instead, the computer-based exam will include a pdf version of the handbook for your use. No printed copies of the handbook will be allowed in the exam room.

The pdf version of the *PE Electrical and Computer: Power Reference Handbook* that you use on exam day will be very similar to this one. However, pages not needed to solve exam questions—such as the cover and introductory material—may not be included in the exam version. In addition, NCEES will periodically revise and update the handbook, and each Electrical and Computer: Power exam will be administered using the updated version.

The *PE Electrical and Computer: Power Reference Handbook* does not contain all the information required to answer every question on the exam. Theories, conversions, formulas, and definitions that examinees are expected to know have not been included. The handbook is intended solely for use on the NCEES PE Electrical and Computer: Power exam.

Other Supplied Exam Material

In addition to the *PE Electrical and Computer: Power Reference Handbook*, the exam will include codes and standards for your use. A list of the material that will be included in your exam is available at ncees.org in the exam specifications. Any additional material required for the solution of a particular exam question will be included in the question itself. You will not be allowed to bring personal copies of any material into the exam room.

Updates on Exam Content and Procedures

NCEES.org is our home on the web. Visit us there for updates on everything exam-related, including specifications, exam-day policies, scoring, and practice tests.

Errata

To report errata in this book, send your correction on a help ticket in your MyNCEES account on NCEES.org. Examinees are not penalized for any errors in the handbook that affect an exam question.



CONTENTS

1	GENERAL ENGINEERING	1
1.1	Units	1
1.2	Conversion Factor	2
1.3	Mathematics	3
1.3.1	Algebra of Complex Numbers	3
1.3.2	Trigonometry	4
1.3.3	List of Derivatives	6
1.3.4	List of Indefinite Integrals	7
1.4	Engineering Economics	8
1.4.1	Nomenclature and Definitions	8
1.4.2	Non-Annual Compounding	9
1.4.3	Breakeven Analysis	9
1.4.4	Inflation	9
1.4.5	Depreciation	9
1.4.6	Book Value	10
1.4.7	Taxation	10
1.4.8	Capitalized Costs	10
1.4.9	Bonds	10
1.4.10	Rate-of-Return	10
1.4.11	Benefit-Cost Analysis	10
1.4.12	Interest Rate Tables	11
2	GENERAL POWER ENGINEERING	16
2.1	Measurement and Instrumentation	16
2.1.1	Insulation Testing	16
2.1.2	Ground Resistance Testing	19
2.2	Applications	21
2.2.1	Lightning Protection	21
2.2.2	Reliability	22
2.2.3	Illumination and Energy Efficiency	23
2.2.4	Demand Calculations	26

Contents

2.2.5	Energy Management	27
2.2.6	Grounding	28
2.3	Codes and Standards	32
3	CIRCUITS	33
3.1	Analysis	33
3.1.1	3-Phase Circuits	33
3.1.2	Symmetrical Components	34
3.1.3	Per Unit System	34
3.1.4	Single-Phase Circuits	35
3.1.5	DC Circuits	37
3.1.6	Single-Line Diagrams	38
3.2	Devices and Power Electronic Circuits	39
3.2.1	Battery Characteristics and Ratings	39
3.2.2	Power Supplies and Converters	44
3.2.3	Variable-Speed Drives	48
4	ROTATING MACHINES AND ELECTRIC POWER DEVICES	49
4.1	Synchronous Machines	49
4.1.1	Generator and Motor Applications	50
4.1.2	Equivalent Circuits and Characteristics	50
4.1.3	Motor Starting	51
4.1.4	Electrical Machine Theory	51
4.2	Induction Machines	52
4.2.1	Generator and Motor Applications	52
4.2.2	Equivalent Circuits and Characteristics	53
4.2.3	Motor Starting	54
4.2.4	Electrical Machine Theory	55
4.2.5	3-Phase Induction Motor Power Flow	56
4.3	Electric Power Devices	57
4.3.1	Transformers	57
4.3.2	Reactors	61
4.3.3	Testing	62
4.3.4	Capacitors	63

5 TRANSMISSION AND DISTRIBUTION 64

5.1 Power System Analysis 64

5.1.1 Voltage Drop 64

5.1.2 Voltage Regulation 64

5.1.3 Power Factor Correction and Voltage Support 64

5.1.4 Power Quality 65

5.1.5 Fault Current Analysis 65

5.1.6 Transmission Line Models 69

5.1.7 Transmission Line Parameters 72

5.1.8 Line Inductance and Inductive Reactance 72

5.1.9 Power Flow 73

5.1.10 Power System Stability 74

1 GENERAL ENGINEERING

1.1 Units

METRIC PREFIXES		
Multiple	Prefix	Symbol
10^{-18}	atto	a
10^{-15}	femto	f
10^{-12}	pico	p
10^{-9}	nano	n
10^{-6}	micro	μ
10^{-3}	milli	m
10^{-2}	centi	c
10^{-1}	deci	d
10^1	deka	da
10^2	hecto	h
10^3	kilo	k
10^6	mega	M
10^9	giga	G
10^{12}	tera	T
10^{15}	peta	P
10^{18}	exa	E

TEMPERATURE CONVERSIONS
$^{\circ}\text{F} = 1.8 (^{\circ}\text{C}) + 32$
$^{\circ}\text{C} = (^{\circ}\text{F} - 32)/1.8$
$^{\circ}\text{R} = ^{\circ}\text{F} + 459.69$
$\text{K} = ^{\circ}\text{C} + 273.15$

The PE exam and this handbook use both the metric system of units and the U.S. Customary System (USCS). In the USCS system of units, both force and mass are called pounds. Therefore, one must distinguish the pound-force (lbf) from the pound-mass (lbm).

The pound-force is that force which accelerates one pound-mass at 32.174 ft/sec^2 . Thus, $1 \text{ lbf} = 32.174 \text{ lbm-ft/sec}^2$. The expression $32.174 \text{ lbm-ft/(lbf-sec}^2)$ is designated as g_c and is used to resolve expressions involving both mass and force expressed as pounds. For instance, in writing Newton's second law, the equation would be written as $F = ma/g_c$, where F is in lbf, m in lbm, and a is in ft/sec^2 .

Similar expressions exist for other quantities: kinetic energy, $\text{KE} = mv^2/2g_c$, with KE in (ft-lbf); potential energy, $\text{PE} = mgh/g_c$, with PE in (ft-lbf); fluid pressure, $p = \rho gh/g_c$, with p in (lbf/ft²); specific weight, $\text{SW} = \rho g/g_c$, in (lbf/ft³); shear stress, $\tau = (\mu/g_c)(dv/dy)$, with shear stress in (lbf/ft²). In all these examples, g_c should be regarded as a force unit conversion factor. It is frequently not written explicitly in engineering equations. However, its use is required to produce a consistent set of units.

Note that the force unit conversion factor g_c [$\text{lbm-ft/(lbf-sec}^2)$] should not be confused with the local acceleration of gravity g , which has different units (m/s^2 or ft/sec^2) and may be either its standard value (9.807 m/s^2 or 32.174 ft/sec^2) or some other local value.

If the problem is presented in USCS units, it may be necessary to use the constant g_c in the equation to have a consistent set of units.

1.2 Conversion Factor

Multiply	By	To Obtain
ampere-hr (A-hr)	3,600	coulomb (C)
cal	4.186	joule (J)
cal/sec	4.184	watt (W)
centimeter (cm)	3.281×10^{-2}	foot (ft)
cm	0.394	inch (in)
foot (ft)	30.48	cm
ft	0.3048	meter (m)
ft-lbf/sec	1.818×10^{-3}	horsepower (hp)
gauss	1×10^{-4}	tesla (T)
gram (g)	2.205×10^{-3}	pound (lbm)
hp	745.7	watt (W)
hp	33,000	(ft-lbf)/min
hp	550	(ft-lbf)/sec
inch (in.)	2.540	centimeter (cm)
J/s	1	watt (W)
kilogram (kg)	2.205	pound-mass (lbm)
kilowatt (kW)	1.341	horsepower (hp)
kW	737.6	(ft-lbf)/sec
meter (m)	3.281	feet (ft)
m/second (m/s)	196.8	feet/min (ft/min)
mile (statute)	5,280	feet (ft)
mile (statute)	1.609	kilometer (km)
newton (N)	1	$\text{kg}\cdot\text{m}/\text{s}^2$
N•m	0.7376	ft-lbf
pound (lbm, avdp)	0.454	kilogram (kg)
lbf	4.448	N
lbf-ft	1.356	N•m
radian	$180/\pi$	degree
watt (W)	1.341×10^{-3}	horsepower (hp)
watt (W)	1	joule/s (J/s)
weber/m ² (Wb/m ²)	10,000	gauss

1.3 Mathematics

1.3.1 Algebra of Complex Numbers

Complex numbers may be designated in rectangular form or polar form. In rectangular form, a complex number is written in terms of its real and imaginary components.

$$z = a + jb$$

where

a = the real component

b = the imaginary component

$$j = \sqrt{-1} \text{ (some disciplines use } i = \sqrt{-1}\text{)}$$

In polar form,

$$z = c \angle \theta$$

where

$$c = \sqrt{a^2 + b^2}$$

$$\theta = \tan^{-1}(b/a)$$

$$a = c \cos \theta$$

$$b = c \sin \theta$$

Complex numbers can be added and subtracted in rectangular form. If

$$z_1 = a_1 + jb_1 = c_1 (\cos \theta_1 + j \sin \theta_1)$$

$$= c_1 \angle \theta_1 \text{ and}$$

$$z_2 = a_2 + jb_2 = c_2 (\cos \theta_2 + j \sin \theta_2)$$

$$= c_2 \angle \theta_2, \text{ then}$$

$$z_1 + z_2 = (a_1 + a_2) + j(b_1 + b_2) \text{ and}$$

$$z_1 - z_2 = (a_1 - a_2) + j(b_1 - b_2)$$

While complex numbers can be multiplied or divided in rectangular form, it is more convenient to perform these operations in polar form.

$$z_1 \times z_2 = (c_1 \times c_2) \angle (\theta_1 + \theta_2)$$

$$z_1/z_2 = (c_1/c_2) \angle (\theta_1 - \theta_2)$$

The complex conjugate of a complex number $z_1 = (a_1 + jb_1)$ is defined as:

$$z_1^* = (a_1 - jb_1)$$

The product of a complex number and its complex conjugate is:

$$z_1 z_1^* = a_1^2 + b_1^2$$

1.3.1.1 Polar Coordinate System

$$x = r \cos \theta$$

$$y = r \sin \theta$$

$$\theta = \arctan (y/x)$$

$$r = |x + jy| = \sqrt{x^2 + y^2}$$

$$x + jy = r (\cos \theta + j \sin \theta) = r e^{j\theta}$$

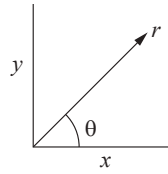

$$[r_1(\cos \theta_1 + j \sin \theta_1)][r_2(\cos \theta_2 + j \sin \theta_2)] = r_1 r_2 [\cos (\theta_1 + \theta_2) + j \sin (\theta_1 + \theta_2)]$$

$$(x + jy)^n = [r (\cos \theta + j \sin \theta)]^n$$

$$= r^n (\cos n\theta + j \sin n\theta)$$

$$\frac{r_1 (\cos \theta_1 + j \sin \theta_1)}{r_2 (\cos \theta_2 + j \sin \theta_2)} = \frac{r_1}{r_2} [\cos (\theta_1 - \theta_2) + j \sin (\theta_1 - \theta_2)]$$

1.3.1.2 Euler's Identity

$$e^{j\theta} = \cos \theta + j \sin \theta$$

$$e^{-j\theta} = \cos \theta - j \sin \theta$$

$$\cos \theta = \frac{e^{j\theta} + e^{-j\theta}}{2}$$

$$\sin \theta = \frac{e^{j\theta} - e^{-j\theta}}{2j}$$

1.3.1.3 Roots

If k is any positive integer, any complex number (other than zero) has k distinct roots. The k roots of $r (\cos \theta + j \sin \theta)$ can be found by substituting successively $n = 0, 1, 2, \dots, (k - 1)$ in the formula

$$w = \sqrt[k]{r} \left[\cos \left(\frac{\theta}{k} + n \frac{360^\circ}{k} \right) + j \sin \left(\frac{\theta}{k} + n \frac{360^\circ}{k} \right) \right]$$

1.3.2 Trigonometry

Trigonometric functions are defined using a right triangle.

$$\sin \theta = y/r, \cos \theta = x/r$$

$$\tan \theta = y/x, \cot \theta = x/y$$

$$\csc \theta = r/y, \sec \theta = r/x$$

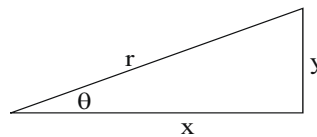

Law of Sines

$$\frac{a}{\sin A} = \frac{b}{\sin B} = \frac{c}{\sin C}$$

Law of Cosines

$$a^2 = b^2 + c^2 - 2bc \cos A$$

$$b^2 = a^2 + c^2 - 2ac \cos B$$

$$c^2 = a^2 + b^2 - 2ab \cos C$$

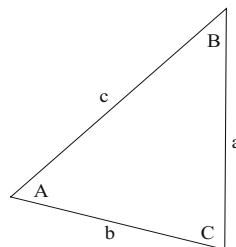

Brink, R.W., *A First Year of College Mathematics*, D. Appleton-Century Co., Inc., Englewood Cliffs, NJ, 1937.

1.3.2.1 Identities

$$\begin{aligned} \cos \theta &= \sin (\theta + \pi/2) = -\sin (\theta - \pi/2) \\ \sin \theta &= \cos (\theta - \pi/2) = -\cos (\theta + \pi/2) \\ \csc \theta &= 1/\sin \theta \\ \sec \theta &= 1/\cos \theta \\ \tan \theta &= \sin \theta/\cos \theta \\ \cot \theta &= 1/\tan \theta \\ \sin^2 \theta + \cos^2 \theta &= 1 \\ \tan^2 \theta + 1 &= \sec^2 \theta \\ \cot^2 \theta + 1 &= \csc^2 \theta \\ \sin (\alpha + \beta) &= \sin \alpha \cos \beta + \cos \alpha \sin \beta \\ \cos (\alpha + \beta) &= \cos \alpha \cos \beta - \sin \alpha \sin \beta \\ \sin 2\alpha &= 2 \sin \alpha \cos \alpha \\ \cos 2\alpha &= \cos^2 \alpha - \sin^2 \alpha = 1 - 2 \sin^2 \alpha = 2 \cos^2 \alpha - 1 \\ \tan 2\alpha &= (2 \tan \alpha)/(1 - \tan^2 \alpha) \\ \cot 2\alpha &= (\cot^2 \alpha - 1)/(2 \cot \alpha) \\ \tan (\alpha + \beta) &= (\tan \alpha + \tan \beta)/(1 - \tan \alpha \tan \beta) \\ \cot (\alpha + \beta) &= (\cot \alpha \cot \beta - 1)/(\cot \alpha + \cot \beta) \\ \sin (\alpha - \beta) &= \sin \alpha \cos \beta - \cos \alpha \sin \beta \\ \cos (\alpha - \beta) &= \cos \alpha \cos \beta + \sin \alpha \sin \beta \\ \tan (\alpha - \beta) &= (\tan \alpha - \tan \beta)/(1 + \tan \alpha \tan \beta) \\ \cot (\alpha - \beta) &= (\cot \alpha \cot \beta + 1)/(\cot \beta - \cot \alpha) \\ \sin (\alpha/2) &= \pm \sqrt{(1 - \cos \alpha)/2} \\ \cos (\alpha/2) &= \pm \sqrt{(1 + \cos \alpha)/2} \\ \tan (\alpha/2) &= \pm \sqrt{(1 - \cos \alpha)/(1 + \cos \alpha)} \\ \cot (\alpha/2) &= \pm \sqrt{(1 + \cos \alpha)/(1 - \cos \alpha)} \\ \sin \alpha \sin \beta &= (1/2)[\cos (\alpha - \beta) - \cos (\alpha + \beta)] \\ \cos \alpha \cos \beta &= (1/2)[\cos (\alpha - \beta) + \cos (\alpha + \beta)] \\ \sin \alpha \cos \beta &= (1/2)[\sin (\alpha + \beta) + \sin (\alpha - \beta)] \\ \sin \alpha + \sin \beta &= 2 \sin [(1/2)(\alpha + \beta)] \cos [(1/2)(\alpha - \beta)] \\ \sin \alpha - \sin \beta &= 2 \cos [(1/2)(\alpha + \beta)] \sin [(1/2)(\alpha - \beta)] \\ \cos \alpha + \cos \beta &= 2 \cos [(1/2)(\alpha + \beta)] \cos [(1/2)(\alpha - \beta)] \\ \cos \alpha - \cos \beta &= -2 \sin [(1/2)(\alpha + \beta)] \sin [(1/2)(\alpha - \beta)] \\ \sinh (x) &= (e^x - e^{-x})/2 \\ \cosh (x) &= (e^x + e^{-x})/2 \\ \cosh^2 (x) - \sinh^2 (x) &= 1 \\ \sinh (x \pm y) &= \sinh (x) \cosh (y) \pm \cosh (x) \sinh (y) \\ \cosh (x \pm y) &= \cosh (x) \cosh (y) \pm \sinh (x) \sinh (y) \end{aligned}$$

1.3.3 List of Derivatives

In these formulas, u , v , and w represent functions of x . Also, a , c , and n represent constants. All arguments of the trigonometric functions are in radians. A constant of integration should be added to the integrals. To avoid terminology difficulty, the following definitions are observed: $\arcsin u = \sin^{-1} u$, $(\sin u)^{-1} = 1/\sin u$.

1. $dc/dx = 0$
2. $dx/dx = 1$
3. $d(cu)/dx = c du/dx$
4. $d(u + v - w)/dx = du/dx + dv/dx - dw/dx$
5. $d(uv)/dx = u dv/dx + v du/dx$
6. $d(uvw)/dx = uv dw/dx + uw dv/dx + vw du/dx$
7. $\frac{d(u/v)}{dx} = \frac{v du/dx - u dv/dx}{v^2}$
8. $d(u^n)/dx = nu^{n-1} du/dx$
9. $d[f(u)]/dx = \{d[f(u)]/du\} du/dx$
10. $du/dx = 1/(dx/du)$
11. $\frac{d(\log_a u)}{dx} = (\log_a e) \frac{1}{u} \frac{du}{dx}$
12. $\frac{d(\ln u)}{dx} = \frac{1}{u} \frac{du}{dx}$
13. $\frac{d(a^u)}{dx} = (\ln a) a^u \frac{du}{dx}$
14. $d(e^u)/dx = e^u du/dx$
15. $d(u^v)/dx = vu^{v-1} du/dx + (\ln u) u^v dv/dx$
16. $d(\sin u)/dx = \cos u du/dx$
17. $d(\cos u)/dx = -\sin u du/dx$
18. $d(\tan u)/dx = \sec^2 u du/dx$
19. $d(\cot u)/dx = -\csc^2 u du/dx$
20. $d(\sec u)/dx = \sec u \tan u du/dx$
21. $d(\csc u)/dx = -\csc u \cot u du/dx$
22. $\frac{d(\sin^{-1} u)}{dx} = \frac{1}{\sqrt{1-u^2}} \frac{du}{dx} \quad (-\pi/2 \leq \sin^{-1} u \leq \pi/2)$
23. $\frac{d(\cos^{-1} u)}{dx} = -\frac{1}{\sqrt{1-u^2}} \frac{du}{dx} \quad (0 \leq \cos^{-1} u \leq \pi)$
24. $\frac{d(\tan^{-1} u)}{dx} = \frac{1}{1+u^2} \frac{du}{dx} \quad (-\pi/2 < \tan^{-1} u < \pi/2)$
25. $\frac{d(\cot^{-1} u)}{dx} = -\frac{1}{1+u^2} \frac{du}{dx} \quad (0 < \cot^{-1} u < \pi)$
26. $\frac{d(\sec^{-1} u)}{dx} = \frac{1}{u\sqrt{u^2-1}} \frac{du}{dx} \quad (0 < \sec^{-1} u < \pi/2)(-\pi \leq \sec^{-1} u < -\pi/2)$
27. $\frac{d(\csc^{-1} u)}{dx} = -\frac{1}{u\sqrt{u^2-1}} \frac{du}{dx} \quad (0 < \csc^{-1} u \leq \pi/2)(-\pi < \csc^{-1} u \leq -\pi/2)$

1.3.4 List of Indefinite Integrals

1. $\int df(x) = f(x)$
2. $\int dx = x$
3. $\int a f(x) dx = a \int f(x) dx$
4. $\int [u(x) \pm v(x)] dx = \int u(x) dx \pm \int v(x) dx$
5. $\int x^m dx = \frac{x^{m+1}}{m+1} \quad (m \neq -1)$
6. $\int u(x) dv(x) = u(x)v(x) - \int v(x) du(x)$
7. $\int \frac{dx}{ax+b} = \frac{1}{a} \ln |ax+b|$
8. $\int \frac{dx}{\sqrt{x}} = 2\sqrt{x}$
9. $\int a^x dx = \frac{a^x}{\ln a}$
10. $\int \sin x dx = -\cos x$
11. $\int \cos x dx = \sin x$
12. $\int \sin^2 x dx = \frac{x}{2} - \frac{\sin 2x}{4}$
13. $\int \cos^2 x dx = \frac{x}{2} + \frac{\sin 2x}{4}$
14. $\int x \sin x dx = \sin x - x \cos x$
15. $\int x \cos x dx = \cos x + x \sin x$
16. $\int \sin x \cos x dx = (\sin^2 x)/2$
17. $\int \sin ax \cos bx dx = -\frac{\cos(a-b)x}{2(a-b)} - \frac{\cos(a+b)x}{2(a+b)} \quad (a^2 \neq b^2)$
18. $\int \tan x dx = -\ln |\cos x| = \ln |\sec x|$
19. $\int \cot x dx = -\ln |\csc x| = \ln |\sin x|$
20. $\int \tan^2 x dx = \tan x - x$
21. $\int \cot^2 x dx = -\cot x - x$
22. $\int e^{ax} dx = (1/a) e^{ax}$
23. $\int x e^{ax} dx = (e^{ax}/a^2)(ax - 1)$
24. $\int \ln x dx = x [\ln(x) - 1] \quad (x > 0)$
25. $\int \frac{dx}{a^2 + x^2} = \frac{1}{a} \tan^{-1} \frac{x}{a} \quad (a \neq 0)$
26. $\int \frac{dx}{ax^2 + c} = \frac{1}{\sqrt{ac}} \tan^{-1} \left(x \sqrt{\frac{a}{c}} \right) \quad (a > 0, c > 0)$
- 27a. $\int \frac{dx}{ax^2 + bx + c} = \frac{2}{\sqrt{4ac - b^2}} \tan^{-1} \frac{2ax + b}{\sqrt{4ac - b^2}} \quad (4ac - b^2 > 0)$
- 27b. $\int \frac{dx}{ax^2 + bx + c} = \frac{1}{\sqrt{b^2 - 4ac}} \ln \left| \frac{2ax + b - \sqrt{b^2 - 4ac}}{2ax + b + \sqrt{b^2 - 4ac}} \right| \quad (b^2 - 4ac > 0)$
- 27c. $\int \frac{dx}{ax^2 + bx + c} = -\frac{2}{2ax + b}, \quad (b^2 - 4ac = 0)$

1.4 Engineering Economics

Factor Name	Converts	Symbol	Formula
Single Payment Compound Amount	to F given P	$(F/P, i\%, n)$	$(1 + i)^n$
Single Payment Present Worth	to P given F	$(P/F, i\%, n)$	$(1 + i)^{-n}$
Uniform Series Sinking Fund	to A given F	$(A/F, i\%, n)$	$\frac{i}{(1 + i)^n - 1}$
Capital Recovery	to A given P	$(A/P, i\%, n)$	$\frac{i(1 + i)^n}{(1 + i)^n - 1}$
Uniform Series Compound Amount	to F given A	$(F/A, i\%, n)$	$\frac{(1 + i)^n - 1}{i}$
Uniform Series Present Worth	to P given A	$(P/A, i\%, n)$	$\frac{(1 + i)^n - 1}{i(1 + i)^n}$
Uniform Gradient Present Worth	to P given G	$(P/G, i\%, n)$	$\frac{(1 + i)^n - 1}{i^2(1 + i)^n} - \frac{n}{i(1 + i)^n}$
Uniform Gradient † Future Worth	to F given G	$(F/G, i\%, n)$	$\frac{(1 + i)^n - 1}{i^2} - \frac{n}{i}$
Uniform Gradient Uniform Series	to A given G	$(A/G, i\%, n)$	$\frac{1}{i} - \frac{n}{(1 + i)^n - 1}$

† $F/G = (F/A - n)/i = (F/A) \times (A/G)$

1.4.1 Nomenclature and Definitions

- AUniform amount per interest period
- BBenefit
- BVBook value
- CCost
- dInflation-adjusted interest rate per interest period
- D_jDepreciation in year j
- EVExpected value
- FFuture worth, value, or amount
- fGeneral inflation rate per interest period
- GUniform gradient amount per interest period
- iInterest rate per interest period
- i_eAnnual effective interest rate
- MARR....Minimum acceptable/attractive rate of return
- mNumber of compounding periods per year
- nNumber of compounding periods; or the expected life of an asset
- PPresent worth, value, or amount
- rNominal annual interest rate
- S_nExpected salvage value in year n

1.4.1.1 Subscripts

j at time j

n at time n

1.4.1.2 Risk

Risk is the chance of an outcome other than what is planned to occur or expected in the analysis.

1.4.2 Non-Annual Compounding

$$i_e = \left(1 + \frac{r}{m}\right)^m - 1$$

1.4.3 Breakeven Analysis

By altering the value of any one of the variables in a situation, holding all of the other values constant, it is possible to find a value for that variable that makes the two alternatives equally economical. This value is the breakeven point.

Breakeven analysis is used to describe the percentage of capacity of operation for a manufacturing plant at which income will just cover expenses.

The payback period is the period of time required for the profit or other benefits of an investment to equal the cost of the investment.

1.4.4 Inflation

To account for inflation, the dollars are deflated by the general inflation rate per interest period f , and then they are shifted over the time scale using the interest rate per interest period i . Use an inflation-adjusted interest rate per interest period d for computing present worth values P .

The formula for d is $d = i + f + (i \times f)$

1.4.5 Depreciation

1.4.5.1 Straight Line

$$D_j = \frac{C - S_n}{n}$$

1.4.5.2 Modified Accelerated Cost Recovery System (MACRS)

$$D_j = (\text{factor}) C$$

A table of MACRS factors is provided below.

MACRS FACTORS				
Year	Recovery Period (Years)			
	3	5	7	10
	Recovery Rate (Percent)			
1	33.33	20.00	14.29	10.00
2	44.45	32.00	24.49	18.00
3	14.81	19.20	17.49	14.40
4	7.41	11.52	12.49	11.52
5		11.52	8.93	9.22
6		5.76	8.92	7.37
7			8.93	6.55
8			4.46	6.55
9				6.56
10				6.55
11				3.28

1.4.6 Book Value

$$BV = \text{initial cost} - \sum D_j$$

1.4.7 Taxation

Income taxes are paid at a specific rate on taxable income. Taxable income is total income less depreciation and ordinary expenses. Expenses do not include capital items, which should be depreciated.

1.4.8 Capitalized Costs

Capitalized costs are present worth values using an assumed perpetual period of time.

$$\text{Capitalized Costs} = P = \frac{A}{i}$$

1.4.9 Bonds

Bond value equals the present worth of the payments the purchaser (or holder of the bond) receives during the life of the bond at some interest rate i .

Bond yield equals the computed interest rate of the bond value when compared with the bond cost.

1.4.10 Rate-of-Return

The minimum acceptable rate-of-return (MARR) is that interest rate that one is willing to accept, or the rate one desires to earn on investments. The rate-of-return on an investment is the interest rate that makes the benefits and costs equal.

1.4.11 Benefit-Cost Analysis

In a benefit-cost analysis, the benefits B of a project should exceed the estimated costs C .

$$B - C \geq 0, \text{ or } B/C \geq 1$$

1.4.12 Interest Rate Tables

Interest Rate Tables
Factor Table - $i = 0.50\%$

n	P/F	P/A	P/G	F/P	F/A	A/P	A/F	A/G
1	0.9950	0.9950	0.0000	1.0050	1.0000	1.0050	1.0000	0.0000
2	0.9901	1.9851	0.9901	1.0100	2.0050	0.5038	0.4988	0.4988
3	0.9851	2.9702	2.9604	1.0151	3.0150	0.3367	0.3317	0.9967
4	0.9802	3.9505	5.9011	1.0202	4.0301	0.2531	0.2481	1.4938
5	0.9754	4.9259	9.8026	1.0253	5.0503	0.2030	0.1980	1.9900
6	0.9705	5.8964	14.6552	1.0304	6.0755	0.1696	0.1646	2.4855
7	0.9657	6.8621	20.4493	1.0355	7.1059	0.1457	0.1407	2.9801
8	0.9609	7.8230	27.1755	1.0407	8.1414	0.1278	0.1228	3.4738
9	0.9561	8.7791	34.8244	1.0459	9.1821	0.1139	0.1089	3.9668
10	0.9513	9.7304	43.3865	1.0511	10.2280	0.1028	0.0978	4.4589
11	0.9466	10.6770	52.8526	1.0564	11.2792	0.0937	0.0887	4.9501
12	0.9419	11.6189	63.2136	1.0617	12.3356	0.0861	0.0811	5.4406
13	0.9372	12.5562	74.4602	1.0670	13.3972	0.0796	0.0746	5.9302
14	0.9326	13.4887	86.5835	1.0723	14.4642	0.0741	0.0691	6.4190
15	0.9279	14.4166	99.5743	1.0777	15.5365	0.0694	0.0644	6.9069
16	0.9233	15.3399	113.4238	1.0831	16.6142	0.0652	0.0602	7.3940
17	0.9187	16.2586	128.1231	1.0885	17.6973	0.0615	0.0565	7.8803
18	0.9141	17.1728	143.6634	1.0939	18.7858	0.0582	0.0532	8.3658
19	0.9096	18.0824	160.0360	1.0994	19.8797	0.0553	0.0503	8.8504
20	0.9051	18.9874	177.2322	1.1049	20.9791	0.0527	0.0477	9.3342
21	0.9006	19.8880	195.2434	1.1104	22.0840	0.0503	0.0453	9.8172
22	0.8961	20.7841	214.0611	1.1160	23.1944	0.0481	0.0431	10.2993
23	0.8916	21.6757	233.6768	1.1216	24.3104	0.0461	0.0411	10.7806
24	0.8872	22.5629	254.0820	1.1272	25.4320	0.0443	0.0393	11.2611
25	0.8828	23.4456	275.2686	1.1328	26.5591	0.0427	0.0377	11.7407
30	0.8610	27.7941	392.6324	1.1614	32.2800	0.0360	0.0310	14.1265
40	0.8191	36.1722	681.3347	1.2208	44.1588	0.0276	0.0226	18.8359
50	0.7793	44.1428	1,035.6966	1.2832	56.6452	0.0227	0.0177	23.4624
60	0.7414	51.7256	1,448.6458	1.3489	69.7700	0.0193	0.0143	28.0064
100	0.6073	78.5426	3,562.7934	1.6467	129.3337	0.0127	0.0077	45.3613

Factor Table - $i = 1.00\%$

n	P/F	P/A	P/G	F/P	F/A	A/P	A/F	A/G
1	0.9901	0.9901	0.0000	1.0100	1.0000	1.0100	1.0000	0.0000
2	0.9803	1.9704	0.9803	1.0201	2.0100	0.5075	0.4975	0.4975
3	0.9706	2.9410	2.9215	1.0303	3.0301	0.3400	0.3300	0.9934
4	0.9610	3.9020	5.8044	1.0406	4.0604	0.2563	0.2463	1.4876
5	0.9515	4.8534	9.6103	1.0510	5.1010	0.2060	0.1960	1.9801
6	0.9420	5.7955	14.3205	1.0615	6.1520	0.1725	0.1625	2.4710
7	0.9327	6.7282	19.9168	1.0721	7.2135	0.1486	0.1386	2.9602
8	0.9235	7.6517	26.3812	1.0829	8.2857	0.1307	0.1207	3.4478
9	0.9143	8.5650	33.6959	1.0937	9.3685	0.1167	0.1067	3.9337
10	0.9053	9.4713	41.8435	1.1046	10.4622	0.1056	0.0956	4.4179
11	0.8963	10.3676	50.8067	1.1157	11.5668	0.0965	0.0865	4.9005
12	0.8874	11.2551	60.5687	1.1268	12.6825	0.0888	0.0788	5.3815
13	0.8787	12.1337	71.1126	1.1381	13.8093	0.0824	0.0724	5.8607
14	0.8700	13.0037	82.4221	1.1495	14.9474	0.0769	0.0669	6.3384
15	0.8613	13.8651	94.4810	1.1610	16.0969	0.0721	0.0621	6.8143
16	0.8528	14.7179	107.2734	1.1726	17.2579	0.0679	0.0579	7.2886
17	0.8444	15.5623	120.7834	1.1843	18.4304	0.0643	0.0543	7.7613
18	0.8360	16.3983	134.9957	1.1961	19.6147	0.0610	0.0510	8.2323
19	0.8277	17.2260	149.8950	1.2081	20.8109	0.0581	0.0481	8.7017
20	0.8195	18.0456	165.4664	1.2202	22.0190	0.0554	0.0454	9.1694
21	0.8114	18.8570	181.6950	1.2324	23.2392	0.0530	0.0430	9.6354
22	0.8034	19.6604	198.5663	1.2447	24.4716	0.0509	0.0409	10.0998
23	0.7954	20.4558	216.0660	1.2572	25.7163	0.0489	0.0389	10.5626
24	0.7876	21.2434	234.1800	1.2697	26.9735	0.0471	0.0371	11.0237
25	0.7798	22.0232	252.8945	1.2824	28.2432	0.0454	0.0354	11.4831
30	0.7419	25.8077	355.0021	1.3478	34.7849	0.0387	0.0277	13.7557
40	0.6717	32.8347	596.8561	1.4889	48.8864	0.0305	0.0205	18.1776
50	0.6080	39.1961	879.4176	1.6446	64.4632	0.0255	0.0155	22.4363
60	0.5504	44.9550	1,192.8061	1.8167	81.6697	0.0222	0.0122	26.5333
100	0.3697	63.0289	2,605.7758	2.7048	170.4814	0.0159	0.0059	41.3426

Interest Rate Tables
Factor Table - $i = 1.50\%$

n	P/F	P/A	P/G	F/P	F/A	A/P	A/F	A/G
1	0.9852	0.9852	0.0000	1.0150	1.0000	1.0150	1.0000	0.0000
2	0.9707	1.9559	0.9707	1.0302	2.0150	0.5113	0.4963	0.4963
3	0.9563	2.9122	2.8833	1.0457	3.0452	0.3434	0.3284	0.9901
4	0.9422	3.8544	5.7098	1.0614	4.0909	0.2594	0.2444	1.4814
5	0.9283	4.7826	9.4229	1.0773	5.1523	0.2091	0.1941	1.9702
6	0.9145	5.6972	13.9956	1.0934	6.2296	0.1755	0.1605	2.4566
7	0.9010	6.5982	19.4018	1.1098	7.3230	0.1516	0.1366	2.9405
8	0.8877	7.4859	26.6157	1.1265	8.4328	0.1336	0.1186	3.4219
9	0.8746	8.3605	32.6125	1.1434	9.5593	0.1196	0.1046	3.9008
10	0.8617	9.2222	40.3675	1.1605	10.7027	0.1084	0.0934	4.3772
11	0.8489	10.0711	48.8568	1.1779	11.8633	0.0993	0.0843	4.8512
12	0.8364	10.9075	58.0571	1.1956	13.0412	0.0917	0.0767	5.3227
13	0.8240	11.7315	67.9454	1.2136	14.2368	0.0852	0.0702	5.7917
14	0.8118	12.5434	78.4994	1.2318	15.4504	0.0797	0.0647	6.2582
15	0.7999	13.3432	89.6974	1.2502	16.6821	0.0749	0.0599	6.7223
16	0.7880	14.1313	101.5178	1.2690	17.9324	0.0708	0.0558	7.1839
17	0.7764	14.9076	113.9400	1.2880	19.2014	0.0671	0.0521	7.6431
18	0.7649	15.6726	126.9435	1.3073	20.4894	0.0638	0.0488	8.0997
19	0.7536	16.4262	140.5084	1.3270	21.7967	0.0609	0.0459	8.5539
20	0.7425	17.1686	154.6154	1.3469	23.1237	0.0582	0.0432	9.0057
21	0.7315	17.9001	169.2453	1.3671	24.4705	0.0559	0.0409	9.4550
22	0.7207	18.6208	184.3798	1.3876	25.8376	0.0537	0.0387	9.9018
23	0.7100	19.3309	200.0006	1.4084	27.2251	0.0517	0.0367	10.3462
24	0.6995	20.0304	216.0901	1.4295	28.6335	0.0499	0.0349	10.7881
25	0.6892	20.7196	232.6310	1.4509	30.0630	0.0483	0.0333	11.2276
30	0.6398	24.0158	321.5310	1.5631	37.5387	0.0416	0.0266	13.3883
40	0.5513	29.9158	524.3568	1.8140	54.2679	0.0334	0.0184	17.5277
50	0.4750	34.9997	749.9636	2.1052	73.6828	0.0286	0.0136	21.4277
60	0.4093	39.3803	988.1674	2.4432	96.2147	0.0254	0.0104	25.0930
100	0.2256	51.6247	1,937.4506	4.4320	228.8030	0.0194	0.0044	37.5295

Factor Table - $i = 2.00\%$

n	P/F	P/A	P/G	F/P	F/A	A/P	A/F	A/G
1	0.9804	0.9804	0.0000	1.0200	1.0000	1.0200	1.0000	0.0000
2	0.9612	1.9416	0.9612	1.0404	2.0200	0.5150	0.4950	0.4950
3	0.9423	2.8839	2.8458	1.0612	3.0604	0.3468	0.3268	0.9868
4	0.9238	3.8077	5.6173	1.0824	4.1216	0.2626	0.2426	1.4752
5	0.9057	4.7135	9.2403	1.1041	5.2040	0.2122	0.1922	1.9604
6	0.8880	5.6014	13.6801	1.1262	6.3081	0.1785	0.1585	2.4423
7	0.8706	6.4720	18.9035	1.1487	7.4343	0.1545	0.1345	2.9208
8	0.8535	7.3255	24.8779	1.1717	8.5830	0.1365	0.1165	3.3961
9	0.8368	8.1622	31.5720	1.1951	9.7546	0.1225	0.1025	3.8681
10	0.8203	8.9826	38.9551	1.2190	10.9497	0.1113	0.0913	4.3367
11	0.8043	9.7868	46.9977	1.2434	12.1687	0.1022	0.0822	4.8021
12	0.7885	10.5753	55.6712	1.2682	13.4121	0.0946	0.0746	5.2642
13	0.7730	11.3484	64.9475	1.2936	14.6803	0.0881	0.0681	5.7231
14	0.7579	12.1062	74.7999	1.3195	15.9739	0.0826	0.0626	6.1786
15	0.7430	12.8493	85.2021	1.3459	17.2934	0.0778	0.0578	6.6309
16	0.7284	13.5777	96.1288	1.3728	18.6393	0.0737	0.0537	7.0799
17	0.7142	14.2919	107.5554	1.4002	20.0121	0.0700	0.0500	7.5256
18	0.7002	14.9920	119.4581	1.4282	21.4123	0.0667	0.0467	7.9681
19	0.6864	15.6785	131.8139	1.4568	22.8406	0.0638	0.0438	8.4073
20	0.6730	16.3514	144.6003	1.4859	24.2974	0.0612	0.0412	8.8433
21	0.6598	17.0112	157.7959	1.5157	25.7833	0.0588	0.0388	9.2760
22	0.6468	17.6580	171.3795	1.5460	27.2990	0.0566	0.0366	9.7055
23	0.6342	18.2922	185.3309	1.5769	28.8450	0.0547	0.0347	10.1317
24	0.6217	18.9139	199.6305	1.6084	30.4219	0.0529	0.0329	10.5547
25	0.6095	19.5235	214.2592	1.6406	32.0303	0.0512	0.0312	10.9745
30	0.5521	22.3965	291.7164	1.8114	40.5681	0.0446	0.0246	13.0251
40	0.4529	27.3555	461.9931	2.2080	60.4020	0.0366	0.0166	16.8885
50	0.3715	31.4236	642.3606	2.6916	84.5794	0.0318	0.0118	20.4420
60	0.3048	34.7609	823.6975	3.2810	114.0515	0.0288	0.0088	23.6961
100	0.1380	43.0984	1,464.7527	7.2446	312.2323	0.0232	0.0032	33.9863

Interest Rate Tables
Factor Table - $i = 4.00\%$

n	P/F	P/A	P/G	F/P	F/A	A/P	A/F	A/G
1	0.9615	0.9615	0.0000	1.0400	1.0000	1.0400	1.0000	0.0000
2	0.9246	1.8861	0.9246	1.0816	2.0400	0.5302	0.4902	0.4902
3	0.8890	2.7751	2.7025	1.1249	3.1216	0.3603	0.3203	0.9739
4	0.8548	3.6299	5.2670	1.1699	4.2465	0.2755	0.2355	1.4510
5	0.8219	4.4518	8.5547	1.2167	5.4163	0.2246	0.1846	1.9216
6	0.7903	5.2421	12.5062	1.2653	6.6330	0.1908	0.1508	2.3857
7	0.7599	6.0021	17.0657	1.3159	7.8983	0.1666	0.1266	2.8433
8	0.7307	6.7327	22.1806	1.3686	9.2142	0.1485	0.1085	3.2944
9	0.7026	7.4353	27.8013	1.4233	10.5828	0.1345	0.0945	3.7391
10	0.6756	8.1109	33.8814	1.4802	12.0061	0.1233	0.0833	4.1773
11	0.6496	8.7605	40.3772	1.5395	13.4864	0.1141	0.0741	4.6090
12	0.6246	9.3851	47.2477	1.6010	15.0258	0.1066	0.0666	5.0343
13	0.6006	9.9856	54.4546	1.6651	16.6268	0.1001	0.0601	5.4533
14	0.5775	10.5631	61.9618	1.7317	18.2919	0.0947	0.0547	5.8659
15	0.5553	11.1184	69.7355	1.8009	20.0236	0.0899	0.0499	6.2721
16	0.5339	11.6523	77.7441	1.8730	21.8245	0.0858	0.0458	6.6720
17	0.5134	12.1657	85.9581	1.9479	23.6975	0.0822	0.0422	7.0656
18	0.4936	12.6593	94.3498	2.0258	25.6454	0.0790	0.0390	7.4530
19	0.4746	13.1339	102.8933	2.1068	27.6712	0.0761	0.0361	7.8342
20	0.4564	13.5903	111.5647	2.1911	29.7781	0.0736	0.0336	8.2091
21	0.4388	14.0292	120.3414	2.2788	31.9692	0.0713	0.0313	8.5779
22	0.4220	14.4511	129.2024	2.3699	34.2480	0.0692	0.0292	8.9407
23	0.4057	14.8568	138.1284	2.4647	36.6179	0.0673	0.0273	9.2973
24	0.3901	15.2470	147.1012	2.5633	39.0826	0.0656	0.0256	9.6479
25	0.3751	15.6221	156.1040	2.6658	41.6459	0.0640	0.0240	9.9925
30	0.3083	17.2920	201.0618	3.2434	56.0849	0.0578	0.0178	11.6274
40	0.2083	19.7928	286.5303	4.8010	95.0255	0.0505	0.0105	14.4765
50	0.1407	21.4822	361.1638	7.1067	152.6671	0.0466	0.0066	16.8122
60	0.0951	22.6235	422.9966	10.5196	237.9907	0.0442	0.0042	18.6972
100	0.0198	24.5050	563.1249	50.5049	1,237.6237	0.0408	0.0008	22.9800

Factor Table - $i = 6.00\%$

n	P/F	P/A	P/G	F/P	F/A	A/P	A/F	A/G
1	0.9434	0.9434	0.0000	1.0600	1.0000	1.0600	1.0000	0.0000
2	0.8900	1.8334	0.8900	1.1236	2.0600	0.5454	0.4854	0.4854
3	0.8396	2.6730	2.5692	1.1910	3.1836	0.3741	0.3141	0.9612
4	0.7921	3.4651	4.9455	1.2625	4.3746	0.2886	0.2286	1.4272
5	0.7473	4.2124	7.9345	1.3382	5.6371	0.2374	0.1774	1.8836
6	0.7050	4.9173	11.4594	1.4185	6.9753	0.2034	0.1434	2.3304
7	0.6651	5.5824	15.4497	1.5036	8.3938	0.1791	0.1191	2.7676
8	0.6274	6.2098	19.8416	1.5938	9.8975	0.1610	0.1010	3.1952
9	0.5919	6.8017	24.5768	1.6895	11.4913	0.1470	0.0870	3.6133
10	0.5584	7.3601	29.6023	1.7908	13.1808	0.1359	0.0759	4.0220
11	0.5268	7.8869	34.8702	1.8983	14.9716	0.1268	0.0668	4.4213
12	0.4970	8.3838	40.3369	2.0122	16.8699	0.1193	0.0593	4.8113
13	0.4688	8.8527	45.9629	2.1329	18.8821	0.1130	0.0530	5.1920
14	0.4423	9.2950	51.7128	2.2609	21.0151	0.1076	0.0476	5.5635
15	0.4173	9.7122	57.5546	2.3966	23.2760	0.1030	0.0430	5.9260
16	0.3936	10.1059	63.4592	2.5404	25.6725	0.0990	0.0390	6.2794
17	0.3714	10.4773	69.4011	2.6928	28.2129	0.0954	0.0354	6.6240
18	0.3505	10.8276	75.3569	2.8543	30.9057	0.0924	0.0324	6.9597
19	0.3305	11.1581	81.3062	3.0256	33.7600	0.0896	0.0296	7.2867
20	0.3118	11.4699	87.2304	3.2071	36.7856	0.0872	0.0272	7.6051
21	0.2942	11.7641	93.1136	3.3996	39.9927	0.0850	0.0250	7.9151
22	0.2775	12.0416	98.9412	3.6035	43.3923	0.0830	0.0230	8.2166
23	0.2618	12.3034	104.7007	3.8197	46.9958	0.0813	0.0213	8.5099
24	0.2470	12.5504	110.3812	4.0489	50.8156	0.0797	0.0197	8.7951
25	0.2330	12.7834	115.9732	4.2919	54.8645	0.0782	0.0182	9.0722
30	0.1741	13.7648	142.3588	5.7435	79.0582	0.0726	0.0126	10.3422
40	0.0972	15.0463	185.9568	10.2857	154.7620	0.0665	0.0065	12.3590
50	0.0543	15.7619	217.4574	18.4202	290.3359	0.0634	0.0034	13.7964
60	0.0303	16.1614	239.0428	32.9877	533.1282	0.0619	0.0019	14.7909
100	0.0029	16.6175	272.0471	339.3021	5,638.3681	0.0602	0.0002	16.3711

Interest Rate Tables
Factor Table - $i = 8.00\%$

n	P/F	P/A	P/G	F/P	F/A	A/P	A/F	A/G
1	0.9259	0.9259	0.0000	1.0800	1.0000	1.0800	1.0000	0.0000
2	0.8573	1.7833	0.8573	1.1664	2.0800	0.5608	0.4808	0.4808
3	0.7938	2.5771	2.4450	1.2597	3.2464	0.3880	0.3080	0.9487
4	0.7350	3.3121	4.6501	1.3605	4.5061	0.3019	0.2219	1.4040
5	0.6806	3.9927	7.3724	1.4693	5.8666	0.2505	0.1705	1.8465
6	0.6302	4.6229	10.5233	1.5869	7.3359	0.2163	0.1363	2.2763
7	0.5835	5.2064	14.0242	1.7138	8.9228	0.1921	0.1121	2.6937
8	0.5403	5.7466	17.8061	1.8509	10.6366	0.1740	0.0940	3.0985
9	0.5002	6.2469	21.8081	1.9990	12.4876	0.1601	0.0801	3.4910
10	0.4632	6.7101	25.9768	2.1589	14.4866	0.1490	0.0690	3.8713
11	0.4289	7.1390	30.2657	2.3316	16.6455	0.1401	0.0601	4.2395
12	0.3971	7.5361	34.6339	2.5182	18.9771	0.1327	0.0527	4.5957
13	0.3677	7.9038	39.0463	2.7196	21.4953	0.1265	0.0465	4.9402
14	0.3405	8.2442	43.4723	2.9372	24.2149	0.1213	0.0413	5.2731
15	0.3152	8.5595	47.8857	3.1722	27.1521	0.1168	0.0368	5.5945
16	0.2919	8.8514	52.2640	3.4259	30.3243	0.1130	0.0330	5.9046
17	0.2703	9.1216	56.5883	3.7000	33.7502	0.1096	0.0296	6.2037
18	0.2502	9.3719	60.8426	3.9960	37.4502	0.1067	0.0267	6.4920
19	0.2317	9.6036	65.0134	4.3157	41.4463	0.1041	0.0241	6.7697
20	0.2145	9.8181	69.0898	4.6610	45.7620	0.1019	0.0219	7.0369
21	0.1987	10.0168	73.0629	5.0338	50.4229	0.0998	0.0198	7.2940
22	0.1839	10.2007	76.9257	5.4365	55.4568	0.0980	0.0180	7.5412
23	0.1703	10.3711	80.6726	5.8715	60.8933	0.0964	0.0164	7.7786
24	0.1577	10.5288	84.2997	6.3412	66.7648	0.0950	0.0150	8.0066
25	0.1460	10.6748	87.8041	6.8485	73.1059	0.0937	0.0137	8.2254
30	0.0994	11.2578	103.4558	10.0627	113.2832	0.0888	0.0088	9.1897
40	0.0460	11.9246	126.0422	21.7245	259.0565	0.0839	0.0039	10.5699
50	0.0213	12.2335	139.5928	46.9016	573.7702	0.0817	0.0017	11.4107
60	0.0099	12.3766	147.3000	101.2571	1,253.2133	0.0808	0.0008	11.9015
100	0.0005	12.4943	155.6107	2,199.7613	27,484.5157	0.0800		12.4545

Factor Table - $i = 10.00\%$

n	P/F	P/A	P/G	F/P	F/A	A/P	A/F	A/G
1	0.9091	0.9091	0.0000	1.1000	1.0000	1.1000	1.0000	0.0000
2	0.8264	1.7355	0.8264	1.2100	2.1000	0.5762	0.4762	0.4762
3	0.7513	2.4869	2.3291	1.3310	3.3100	0.4021	0.3021	0.9366
4	0.6830	3.1699	4.3781	1.4641	4.6410	0.3155	0.2155	1.3812
5	0.6209	3.7908	6.8618	1.6105	6.1051	0.2638	0.1638	1.8101
6	0.5645	4.3553	9.6842	1.7716	7.7156	0.2296	0.1296	2.2236
7	0.5132	4.8684	12.7631	1.9487	9.4872	0.2054	0.1054	2.6216
8	0.4665	5.3349	16.0287	2.1436	11.4359	0.1874	0.0874	3.0045
9	0.4241	5.7590	19.4215	2.3579	13.5735	0.1736	0.0736	3.3724
10	0.3855	6.1446	22.8913	2.5937	15.9374	0.1627	0.0627	3.7255
11	0.3505	6.4951	26.3962	2.8531	18.5312	0.1540	0.0540	4.0641
12	0.3186	6.8137	29.9012	3.1384	21.3843	0.1468	0.0468	4.3884
13	0.2897	7.1034	33.3772	3.4523	24.5227	0.1408	0.0408	4.6988
14	0.2633	7.3667	36.8005	3.7975	27.9750	0.1357	0.0357	4.9955
15	0.2394	7.6061	40.1520	4.1772	31.7725	0.1315	0.0315	5.2789
16	0.2176	7.8237	43.4164	4.5950	35.9497	0.1278	0.0278	5.5493
17	0.1978	8.0216	46.5819	5.0545	40.5447	0.1247	0.0247	5.8071
18	0.1799	8.2014	49.6395	5.5599	45.5992	0.1219	0.0219	6.0526
19	0.1635	8.3649	52.5827	6.1159	51.1591	0.1195	0.0195	6.2861
20	0.1486	8.5136	55.4069	6.7275	57.2750	0.1175	0.0175	6.5081
21	0.1351	8.6487	58.1095	7.4002	64.0025	0.1156	0.0156	6.7189
22	0.1228	8.7715	60.6893	8.1403	71.4027	0.1140	0.0140	6.9189
23	0.1117	8.8832	63.1462	8.9543	79.5430	0.1126	0.0126	7.1085
24	0.1015	8.9847	65.4813	9.8497	88.4973	0.1113	0.0113	7.2881
25	0.0923	9.0770	67.6964	10.8347	98.3471	0.1102	0.0102	7.4580
30	0.0573	9.4269	77.0766	17.4494	164.4940	0.1061	0.0061	8.1762
40	0.0221	9.7791	88.9525	45.2593	442.5926	0.1023	0.0023	9.0962
50	0.0085	9.9148	94.8889	117.3909	1,163.9085	0.1009	0.0009	9.5704
60	0.0033	9.9672	97.7010	304.4816	3,034.8164	0.1003	0.0003	9.8023
100	0.0001	9.9993	99.9202	13,780.6123	137,796.1234	0.1000		9.9927

Interest Rate Tables
Factor Table - $i = 12.00\%$

n	P/F	P/A	P/G	F/P	F/A	A/P	A/F	A/G
1	0.8929	0.8929	0.0000	1.1200	1.0000	1.1200	1.0000	0.0000
2	0.7972	1.6901	0.7972	1.2544	2.1200	0.5917	0.4717	0.4717
3	0.7118	2.4018	2.2208	1.4049	3.3744	0.4163	0.2963	0.9246
4	0.6355	3.0373	4.1273	1.5735	4.7793	0.3292	0.2092	1.3589
5	0.5674	3.6048	6.3970	1.7623	6.3528	0.2774	0.1574	1.7746
6	0.5066	4.1114	8.9302	1.9738	8.1152	0.2432	0.1232	2.1720
7	0.4523	4.5638	11.6443	2.2107	10.0890	0.2191	0.0991	2.5515
8	0.4039	4.9676	14.4714	2.4760	12.2997	0.2013	0.0813	2.9131
9	0.3606	5.3282	17.3563	2.7731	14.7757	0.1877	0.0677	3.2574
10	0.3220	5.6502	20.2541	3.1058	17.5487	0.1770	0.0570	3.5847
11	0.2875	5.9377	23.1288	3.4785	20.6546	0.1684	0.0484	3.8953
12	0.2567	6.1944	25.9523	3.8960	24.1331	0.1614	0.0414	4.1897
13	0.2292	6.4235	28.7024	4.3635	28.0291	0.1557	0.0357	4.4683
14	0.2046	6.6282	31.3624	4.8871	32.3926	0.1509	0.0309	4.7317
15	0.1827	6.8109	33.9202	5.4736	37.2797	0.1468	0.0268	4.9803
16	0.1631	6.9740	36.3670	6.1304	42.7533	0.1434	0.0234	5.2147
17	0.1456	7.1196	38.6973	6.8660	48.8837	0.1405	0.0205	5.4353
18	0.1300	7.2497	40.9080	7.6900	55.7497	0.1379	0.0179	5.6427
19	0.1161	7.3658	42.9979	8.6128	63.4397	0.1358	0.0158	5.8375
20	0.1037	7.4694	44.9676	9.6463	72.0524	0.1339	0.0139	6.0202
21	0.0926	7.5620	46.8188	10.8038	81.6987	0.1322	0.0122	6.1913
22	0.0826	7.6446	48.5543	12.1003	92.5026	0.1308	0.0108	6.3514
23	0.0738	7.7184	50.1776	13.5523	104.6029	0.1296	0.0096	6.5010
24	0.0659	7.7843	51.6929	15.1786	118.1552	0.1285	0.0085	6.6406
25	0.0588	7.8431	53.1046	17.0001	133.3339	0.1275	0.0075	6.7708
30	0.0334	8.0552	58.7821	29.9599	241.3327	0.1241	0.0041	7.2974
40	0.0107	8.2438	65.1159	93.0510	767.0914	0.1213	0.0013	7.8988
50	0.0035	8.3045	67.7624	289.0022	2,400.0182	0.1204	0.0004	8.1597
60	0.0011	8.3240	68.8100	897.5969	7,471.6411	0.1201	0.0001	8.2664
100		8.3332	69.4336	83,522.2657	696,010.5477	0.1200		8.3321

Factor Table - $i = 18.00\%$

n	P/F	P/A	P/G	F/P	F/A	A/P	A/F	A/G
1	0.8475	0.8475	0.0000	1.1800	1.0000	1.1800	1.0000	0.0000
2	0.7182	1.5656	0.7182	1.3924	2.1800	0.6387	0.4587	0.4587
3	0.6086	2.1743	1.9354	1.6430	3.5724	0.4599	0.2799	0.8902
4	0.5158	2.6901	3.4828	1.9388	5.2154	0.3717	0.1917	1.2947
5	0.4371	3.1272	5.2312	2.2878	7.1542	0.3198	0.1398	1.6728
6	0.3704	3.4976	7.0834	2.6996	9.4423	0.2859	0.1059	2.0252
7	0.3139	3.8115	8.9670	3.1855	12.1415	0.2624	0.0824	2.3526
8	0.2660	4.0776	10.8292	3.7589	15.3270	0.2452	0.0652	2.6558
9	0.2255	4.3030	12.6329	4.4355	19.0859	0.2324	0.0524	2.9358
10	0.1911	4.4941	14.3525	5.2338	23.5213	0.2225	0.0425	3.1936
11	0.1619	4.6560	15.9716	6.1759	28.7551	0.2148	0.0348	3.4303
12	0.1372	4.7932	17.4811	7.2876	34.9311	0.2086	0.0286	3.6470
13	0.1163	4.9095	18.8765	8.5994	42.2187	0.2037	0.0237	3.8449
14	0.0985	5.0081	20.1576	10.1472	50.8180	0.1997	0.0197	4.0250
15	0.0835	5.0916	21.3269	11.9737	60.9653	0.1964	0.0164	4.1887
16	0.0708	5.1624	22.3885	14.1290	72.9390	0.1937	0.0137	4.3369
17	0.0600	5.2223	23.3482	16.6722	87.0680	0.1915	0.0115	4.4708
18	0.0508	5.2732	24.2123	19.6731	103.7403	0.1896	0.0096	4.5916
19	0.0431	5.3162	24.9877	23.2144	123.4135	0.1881	0.0081	4.7003
20	0.0365	5.3527	25.6813	27.3930	146.6280	0.1868	0.0068	4.7978
21	0.0309	5.3837	26.3000	32.3238	174.0210	0.1857	0.0057	4.8851
22	0.0262	5.4099	26.8506	38.1421	206.3448	0.1848	0.0048	4.9632
23	0.0222	5.4321	27.3394	45.0076	244.4868	0.1841	0.0041	5.0329
24	0.0188	5.4509	27.7725	53.1090	289.4944	0.1835	0.0035	5.0950
25	0.0159	5.4669	28.1555	62.6686	342.6035	0.1829	0.0029	5.1502
30	0.0070	5.5168	29.4864	143.3706	790.9480	0.1813	0.0013	5.3448
40	0.0013	5.5482	30.5269	750.3783	4,163.2130	0.1802	0.0002	5.5022
50	0.0003	5.5541	30.7856	3,927.3569	21,813.0937	0.1800		5.5428
60	0.0001	5.5553	30.8465	20,555.1400	114,189.6665	0.1800		5.5526
100		5.5556	30.8642	15,424,131.91	85,689,616.17	0.1800		5.5555

2 GENERAL POWER ENGINEERING

2.1 Measurement and Instrumentation

2.1.1 Insulation Testing

2.1.1.1 Insulation Resistance Theory

The insulation resistance tests are usually conducted at constant direct voltages having negative polarity. The insulation equivalent circuit and the components of the measured direct current during the test are shown in the figure below.

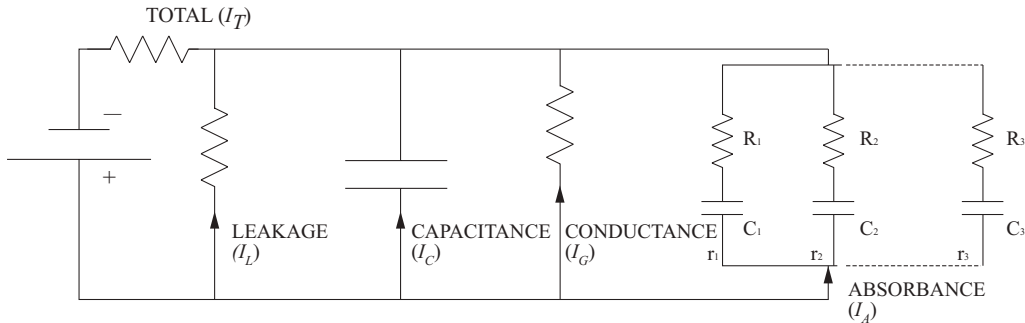

Equivalent circuit showing the four currents monitored during rotating machinery insulation resistance testing

© 2014 IEEE. Reprinted, with permission, from IEEE Std 43™-2013, *IEEE Recommended Practice for Testing Insulation Resistance of Electric Machinery*. p. 5, fig. 1.

The absorption current I_A is:

$$I_A = Kt^{-n}$$

where K is a factor that depends on voltage, capacitance, and the insulation system; t is time; and n depends on the insulation system.

For long measurement times (>10 min) with constant applied voltage, the absorption current often becomes low enough that the total current asymptotically approaches the value of the direct conduction current through the insulation volume and the leakage current through the insulation surface.

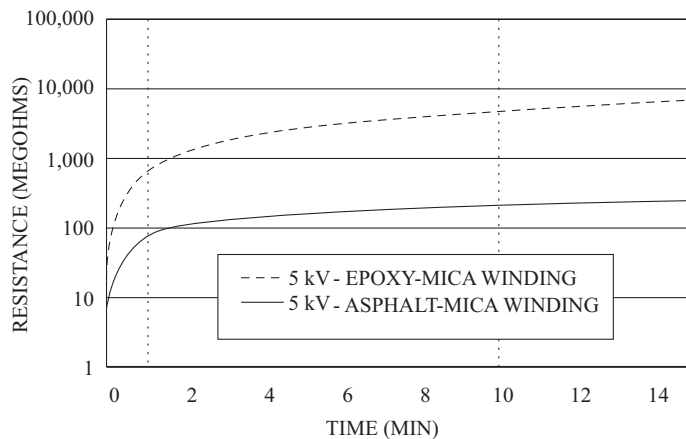

Insulation resistance measurements at 5 kV for same machine before (asphaltic-mica insulation) and after rewinding (epoxy-mica insulation)

© 2014 IEEE. Reprinted, with permission, from IEEE Std 43™-2013, *IEEE Recommended Practice for Testing Insulation Resistance of Electric Machinery*. p. 6, fig. 2.

2.1.1.2 Characteristics of the Measured Direct Current

Comparing the change in insulation resistance or total current with the duration of the test voltage application may be useful in appraising the cleanliness and dryness of a winding. If the windings are contaminated with partially conductive material or are wet, the total current (I_T) will be approximately constant with time, since I_L and/or I_G will be much larger than the absorption current (I_A). If the windings are clean and dry, the total current will normally decrease with time, since the total current is dominated by the absorption (i.e., polarization) current.

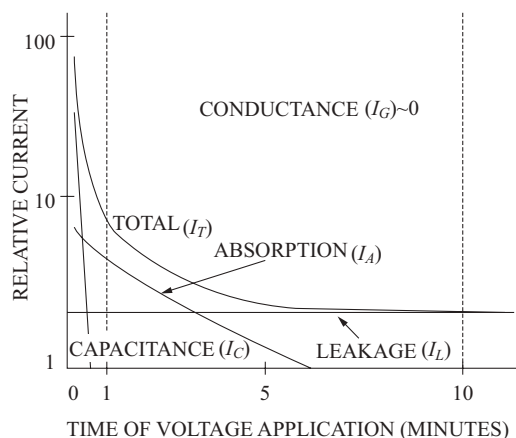

Types of currents for an epoxy-mica insulation with a relatively low current

© 2014 IEEE. Reprinted, with permission, from IEEE Std 43™-2013, IEEE Recommended Practice for Testing Insulation Resistance of Electric Machinery, p. 8, fig. 4.

The following table contains guidelines for direct voltages to be applied during an insulation resistance test.

Winding Rated Voltage (V)*	Insulation Resistance DC Test Voltage (V)
<1000	500
1001–2500	500–1000
2501–5000	1000–2500
5000–12000	2500–5000
>12000	5000–10000
*Rated line-to-line voltage for 3-phase winding Rated line-to-ground voltage for single-phase winding Rated direct voltage for field winding Rated direct voltage for DC machine	

© 2014 IEEE. Reprinted, with permission, from IEEE Std 43™-2013, IEEE Recommended Practice for Testing Insulation Resistance of Electric Machinery, p. 8, Table 1.

The recommended minimum resistance $R_{I-1 \text{ min}}$ in $M\Omega$ is the observed insulation resistance, corrected to 40°C, obtained by applying a constant direct voltage to the entire winding for 1 minute per the following table.

Minimum Insulation Resistance $R_{I-1 \text{ min}}$ ($M\Omega$)	Test Specimen
$R_{I-1 \text{ min}} = kV_{\text{rated}} + 1$	For most windings made before about 1970, all field windings, and others not described below
$R_{I-1 \text{ min}} = 100$	For most ac windings built after about 1970 (form wound coils)
$R_{I-1 \text{ min}} = 5$	For most machines with random-wound stator coils and form wound coils rated below 1 kV and dc armatures

© 2014 IEEE. Reprinted, with permission, from IEEE Std 43™-2013, IEEE Recommended Practice for Testing Insulation Resistance of Electric Machinery, p. 19, Table 4.

It may not be possible to obtain the above minimum $R_{I-1 \text{ min}}$ values for stator windings having extremely large end arm surface areas or for dc armature windings with commutators. For such windings, trending of historical $R_{I-1 \text{ min}}$ values can be used to help evaluate the condition of their insulation. The values in the above table may not be applicable in some cases, specifically when the complete winding overhang is treated with stress control material. The values in the table do not apply to "green" windings before global vacuum impregnation treatment.

2.1.1.3 Effect of Temperature

The insulation resistance value for a given system, at any given point in time, varies inversely, on an exponential basis, with the winding temperature.

Incorporating the effect of temperature, the insulation resistance can be given by:

$$R_I(40^\circ\text{C}) = k(T^\circ\text{C}) R_I(T^\circ\text{C})$$

where

$$R_I(40^\circ\text{C}) = \text{insulation resistance at } 40^\circ\text{C}$$

$$R_I(T^\circ\text{C}) = \text{insulation resistance at } T^\circ\text{C}$$

$$k(T^\circ\text{C}) = \text{insulation resistance temperature coefficient at } T^\circ\text{C}$$

The coefficient $k(T^\circ\text{C})$ can be determined as follows:

For thermosetting insulation systems,

$$k(T^\circ\text{C}) = \exp\left[-4230\left(\frac{1}{T+273} - \frac{1}{313}\right)\right] \text{ for } 40^\circ\text{C} \leq T < 85^\circ\text{C, and}$$

$$k(T^\circ\text{C}) = \exp\left[-1245\left(\frac{1}{T+273} - \frac{1}{313}\right)\right] \text{ for } 10^\circ\text{C} < T < 40^\circ\text{C}$$

For thermoplastic insulation systems,

$$k(T^\circ\text{C}) = 0.5^{(40-T)/10}$$

2.1.1.4 Insulation Polarization Index (PI)

This test applies to new and in-service ac and dc windings that are encased in insulation. The polarization index is the ratio of the 10-minute resistance value ($R_{I-10 \text{ min}}$) to the 1-minute resistance value ($R_{I-1 \text{ min}}$). To provide greater accuracy around the 1-minute point and to allow the data to be plotted on log paper, it is also common to take readings at other intervals such as 15 s, 30 s, 45 s, 1 min, 1.5 min, 2 min, 3 min, 4 min, ... , and 10 min.

$$PI = \frac{R_{I-10 \text{ min}}}{R_{I-1 \text{ min}}}$$

2.1.2 Ground Resistance Testing

Earth resistivity is affected by the type of soil, stratification, moisture content, temperature, and chemical composition.

Three common test methods are the Wenner method, the Schlumberger method, and the Variation of Depth or Driven Rod method.

1. Equally Spaced 4-Pin Method or the Wenner Method (Wenner Array)

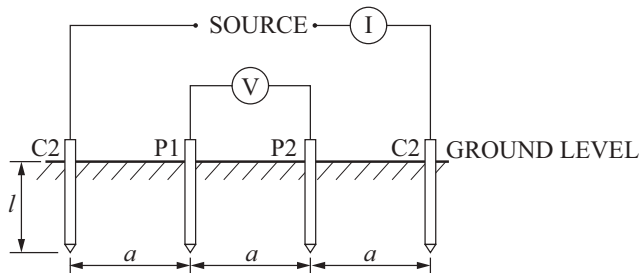

IEEE 80-2013, p. 56, fig. 18, adapted and reprinted with permission from IEEE. Copyright IEEE 2013. All rights reserved.

The measured ground resistance R is given by:

$$R = \frac{V}{I}$$

The apparent resistivity ρ is given by:

$$\rho = \frac{4\pi a R}{1 + \frac{2a}{\sqrt{a^2 + 4l^2}} - \frac{a}{\sqrt{a^2 + l^2}}}$$

Theoretically, the electrodes should be point contacts or hemispherical electrodes of radius equal to l . In practice, the rods are driven to depth $l \leq 0.1a$. Ignoring l , the equation becomes:

$$\rho = 2\pi a R$$

where

R = measured resistance (Ω)

ρ = apparent ground resistivity ($\Omega \cdot m$)

a = probe spacing (m)

V = measured voltage (V)

I = injected current (A)

2. Unequally Spaced 4-Pin Method or the Schlumberger Method (Schlumberger Array)

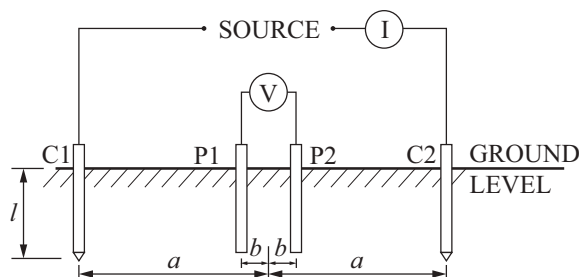

Based on IEEE Std. 81™-1983, *Guide for Measuring Earth Resistivity, Ground Impedance, and Earth Surface Potentials of a Ground System*, fig. 3(b).

$$R = \frac{V}{I}$$

$$\rho = \frac{\pi a(a+2b)R}{2b}$$

Since $a \gg 2b$, the equation becomes:

$$\rho = \frac{\pi a^2 R}{2b}$$

where

R = measured resistance (Ω)

ρ = apparent ground resistivity ($\Omega \cdot \text{m}$)

a = distance from center line to outer probe (m)

b = distance from center line to inner probe (m)

V = measured voltage (V)

I = injected current (A)

3. Variation of Depth Method (Driven Rod Method)

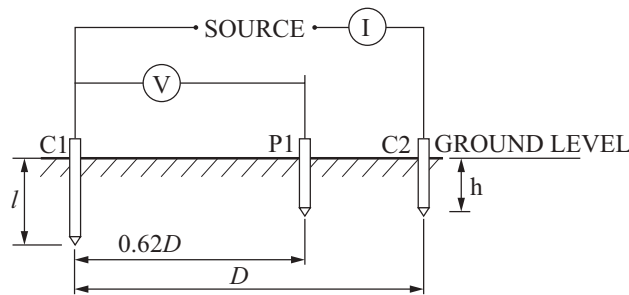

IEEE 80-2013, p. 58, fig. 19, adapted and reprinted with permission from IEEE. Copyright IEEE 2013. All rights reserved.

The ground resistance of the buried rod (C1 in the diagram) can be approximated by:

$$R = \frac{V}{I}$$

The ground resistance of the buried rod can be approximated by:

$$R = \frac{\rho}{2\pi l} \left[\ln\left(\frac{4l}{(d/2)}\right) - 1 \right]$$

and the ground resistivity is:

$$\rho = \frac{2\pi R l}{\ln\left(\frac{4l}{(d/2)}\right) - 1}$$

where

R = measured resistance (Ω)

ρ = apparent ground resistivity ($\Omega \cdot \text{m}$)

D = distance from tested ground to outer probe (m)

d = tested ground electrode diameter (m)

V = measured voltage (V)

I = injected current (A)

2.2 Applications

2.2.1 Lightning Protection

Section 2.2.1 is based on the 2017 edition of NFPA 780, *Standard for the Installation of Lightning Protection Systems*, Annex L. This material is not the complete and official position of the NFPA on the referenced subject, which is represented only by the standard in its entirety. For a full copy, go to www.nfpa.org.

The annual lightning strike frequency N_D to a structure is:

$$N_D = (N_G)(A_D)(C_D) \text{ events/year}$$

where

N_G = annual lightning ground flash density (flashes/unit area/year)

A_D = structure's equivalent collection area

C_D = location factor according to the following table:

Location Factor, C_D

Relative Structure Location	C_D
Structure surrounded by taller structures or trees within a distance of $3H$	0.25
Structure surrounded by structures of equal or lesser height within a distance of $3H$	0.5
Isolated structure, with no other structures located within a distance of $3H$	1
Isolated structure on hilltop	2

The equivalent collection area A_D of a rectangular structure with length L , width W , and height H is:

$$A_D = LW + 6H(L + W) + \pi 9H^2$$

The tolerable lightning frequency N_c is expressed by the following formula:

$$N_c = \frac{1.5 \times 10^{-3}}{C} \text{ events/year}$$

where C is the product of the structural coefficients C_2 , C_3 , C_4 , and C_5 from the tables below.

Determination of Construction Coefficient, C_2

Structure	Construction Coefficient— C_2		
	Metal Roof	Nonmetallic Roof	Combustible Roof
Metal	0.5	1.0	2.0
Nonmetallic	1.0	1.0	2.5
Combustible	2.0	2.5	3.0

Determination of Structure Contents Coefficient, C_3

Structure Contents	C_3
Low value and noncombustible	0.5
Standard value and noncombustible	1.0
High value, moderate combustibility	2.0
Exceptional value, flammable liquids, computer or electronics	3.0
Exceptional value, irreplaceable cultural items	4.0

Determination of Structure Occupancy Coefficient, C_4

Structure Occupancy	C_4
Unoccupied	0.5
Normally occupied	1.0
Difficult to evacuate or risk of panic	3.0

Determination of Lightning Consequence Coefficient, C_5

Lightning Consequence	C_5
Continuity of facility services not required, no environmental impact	1.0
Continuity of facility services required, no environmental impact	5.0
Consequences to the environment	10.0

2.2.2 Reliability

If P_i is the probability that component i is functioning, a reliability function $R(P_1, P_2, \dots, P_n)$ represents the probability that a system consisting of n components will work.

For n independent components connected in series,

$$R(P_1, P_2, \dots, P_n) = \prod_{i=1}^n P_i$$

For n independent components connected in parallel,

$$R(P_1, P_2, \dots, P_n) = 1 - \prod_{i=1}^n (1 - P_i)$$

A system's availability A may be determined as follows:

$$MTTF = \frac{1}{\lambda}$$

$$A = \frac{MTTF}{(MTTF + MTTR)} = \frac{MTTF}{MTBF}$$

where

λ = failure rate (failures/hour)

$MTTF$ = mean time to failure (hours)

$MTTR$ = mean time to repair (hours)

$MTBF$ = mean time between failures (hours)

2.2.3 Illumination and Energy Efficiency

2.2.3.1 Nomenclature

<u>Symbol</u>	<u>Description</u>	<u>Units</u>
CBU	coefficient of beam utilization	—
CCR	ceiling cavity ratio	—
CR	cavity ratio	—
CU	coefficient of utilization	—
E	illumination	fc
E_{rh}	reflected horizontal illumination	fc
E_{rv}	reflected vertical illumination	fc
FCR	floor cavity ratio	—
h_{cc}	ceiling cavity height	feet
h_{fc}	floor cavity height	feet
h_{rc}	room cavity height	feet
H_s	house-side lateral distance	feet
I	luminous intensity	candelas
II	initial illumination level	fc
L	length	feet
L	luminance	foot-lamberts
LC_{cc}	ceiling cavity luminance coefficient	—
LC_w	wall luminance coefficient	—
LDD	luminaire dirt depreciation factor	—
LLD	lamp lumen depreciation factor	—
LLF	light loss factor	—
MH	mounting height	feet
MMI	minimum maintained illumination level	fc

Nomenclature (continued)

<u>Symbol</u>	<u>Description</u>	<u>Units</u>
ND	MH constant <i>short distribution (ND = 5)</i> <i>medium distribution (ND = 10)</i> <i>long distribution (ND = 15)</i>	feet
R	coefficient of reflectance	—
RCR	room cavity ratio	—
RPM	room position multiplier	—
RRC	reflected radiation coefficient	—
S_s	street-side lateral distance	feet
T	coefficient of transmission	—
W	width	feet
$WRRC$	wall reflected radiation coefficient	—
Φ	luminous flux	lumens

2.2.3.2 Calculations

$$E = \frac{I}{D^2} \cdot \cos \theta$$

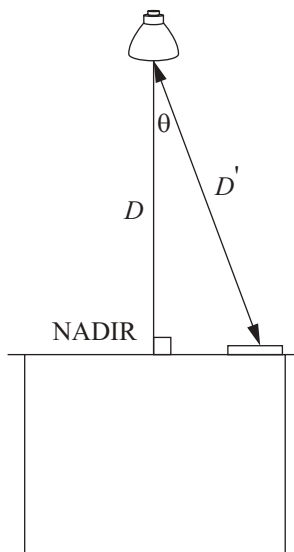

IES Course: Fundamentals of Lighting, Student Manual, p. 39, fig. M6-18, New York: Illuminating Engineering Society, 2015–2018.

$$LLF = LLD \cdot LDD$$

$$II = \frac{MMI}{CU \cdot LDD \cdot LLD}$$

$$\Phi = \frac{II \cdot W \cdot L}{CU}$$

$$CR = 2.5 \cdot \frac{\text{wall area of cavity}}{\text{area of cavity base}}$$

$$RCR = 5h_{rc} \cdot \frac{L+W}{L \cdot W}$$

$$CCR = 5h_{cc} \cdot \frac{L+W}{L \cdot W}$$

$$FCR = 5h_{fc} \cdot \frac{L+W}{L \cdot W}$$

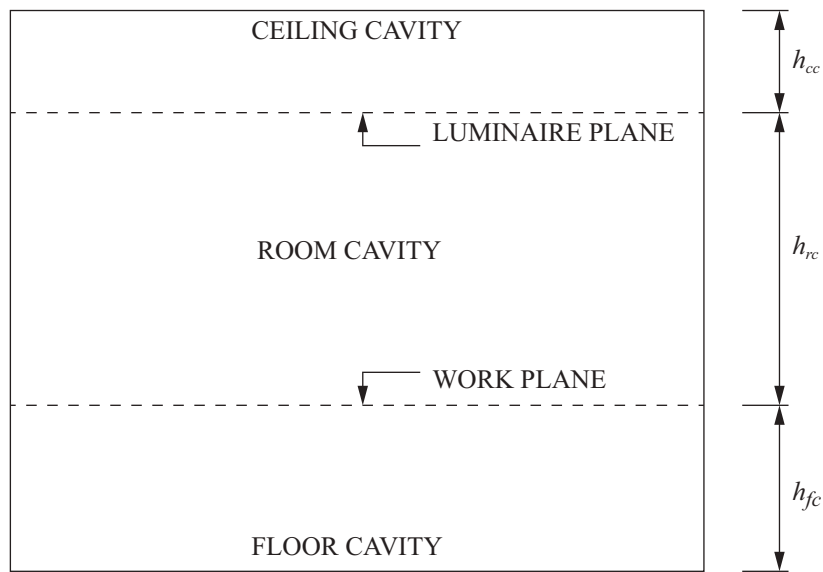

IES Course: Fundamentals of Lighting, Student Manual, p. 23, fig. M6-7, New York: Illuminating Engineering Society, 2015–2018.

$$MMI = \frac{(\# \text{luminaires}) \left(\frac{\text{lamps}}{\text{luminaire}} \right) (\text{initial flux in lumens}) \cdot LLF \cdot CU}{\text{area of working surface in sq. ft.}^*}$$

* Area of the working surface can also be (roadway width) × (spacing) for exterior lighting applications.

$$RRC = LC_w + RPM(LC_{cc} - LC_w)$$

$$\text{min. } MH = \frac{\text{max. candlepower}}{1000} + ND$$

$$\# \text{ floodlights} = \frac{(\text{illumination level})(\text{sq. ft.})}{(\text{beam lumens}) \left(\frac{\text{lamps}}{\text{floodlight}} \right) \cdot LLF \cdot CBU}$$

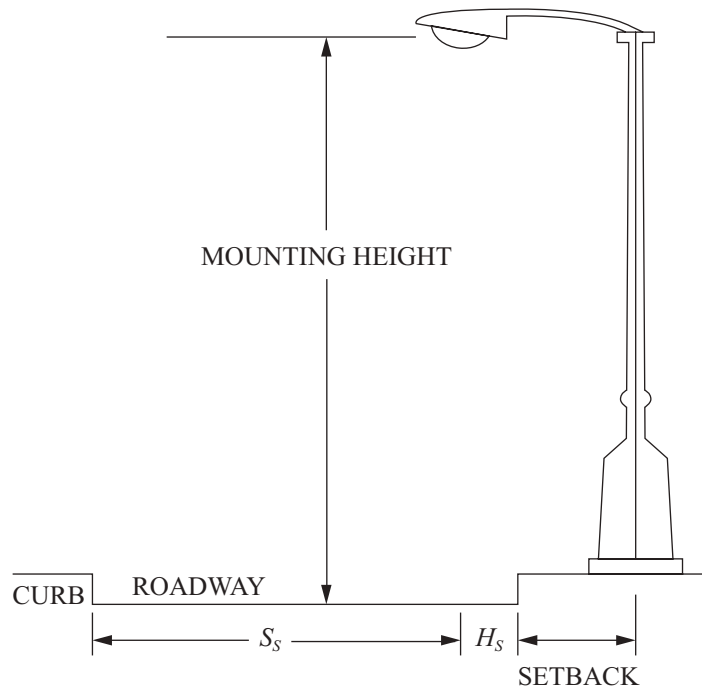

2.2.4 Demand Calculations

The demand factor DF is given by:

$$DF = (\text{maximum demand})/(\text{total connected demand})$$

The utilization factor F_u is given by:

$$F_u = (\text{maximum demand})/(\text{rated system capacity})$$

The plant factor Pf over a period T is given by:

$$Pf = \frac{\text{actual energy produced or served}}{(\text{plant rating}) \cdot T}$$

The load factor FLD is given by:

$$FLD = (\text{average load})/(\text{peak load})$$

The annual load factor is given by:

$$\text{Annual Load Factor} = \frac{\text{total annual energy}}{(\text{peak load}) \cdot 8,760}$$

The diversity factor F_{div} of a system is defined as the ratio of the sum of the individual maximum demands of the various subdivisions of a system to the maximum demand of the whole system.

$$F_{div} = \frac{\sum_{i=1}^n D_{i-\max}}{D_g}$$

where

D_g = coincident maximum demand of a group of n loads

$D_{i-\max}$ = maximum demand of load i regardless of time of occurrence

The coincidence factor F_c is given by:

$$F_c = \frac{D_g}{\sum_{i=1}^n D_{i-\max}} = \frac{1}{F_{div}}$$

The load diversity LD is given by:

$$LD = \sum_{i=1}^n D_{i-\max} - D_g$$

The loss factor FLS is given by:

$$FLS = (\text{average power loss})/(\text{power loss at peak load})$$

Based on Gönen, Turan, *Electric Power Distribution Engineering*, 3 ed., CRC Press, 2014, pp. 37-42.

2.2.5 Energy Management

$$\% \text{ Efficiency} = \frac{P_{\text{out}}}{P_{\text{in}}} \cdot 100$$

where

P_{out} = circuit output power

P_{in} = circuit input power

Energy is the time integral of power:

$$E = \int_0^t P(t) dt$$

where

E = total energy from time 0 to t

$P(t)$ = power as a function of time

2.2.6 Grounding

2.2.6.1 Body Current Limit

Permissible body current limit:

$$I_B = 0.116/\sqrt{t_s} \text{ for persons weighing } \sim 50 \text{ kg (110 lb)}$$

$$I_B = 0.157/\sqrt{t_s} \text{ for persons weighing } \sim 70 \text{ kg (155 lb)}$$

where

$$I_B = \text{body current (A)}$$

$$t_s = \text{duration of the current exposure for 50- to 60-Hz frequency (s)}$$

2.2.6.2 Step Voltage

The maximum allowable step voltage is given by:

$$E_{\text{step}_{50}} = (1000 + 6C_s(h_s K)\rho_s)0.116/\sqrt{t_s} \text{ for persons weighing } \sim 50 \text{ kg(110 lb)}$$

$$E_{\text{step}_{70}} = (1000 + 6C_s(h_s K)\rho_s)0.157/\sqrt{t_s} \text{ for persons weighing } \sim 70 \text{ kg(155 lb)}$$

where

$$K = \frac{\rho - \rho_s}{\rho + \rho_s}$$

$C_s = 1$ for no protective surface layer or approximated from:

$$C_s = 1 - \frac{0.09 \left(1 - \frac{\rho}{\rho_s}\right)}{2h_s + 0.09}$$

or determined from the following figure, assuming a foot radius of 0.08 m.

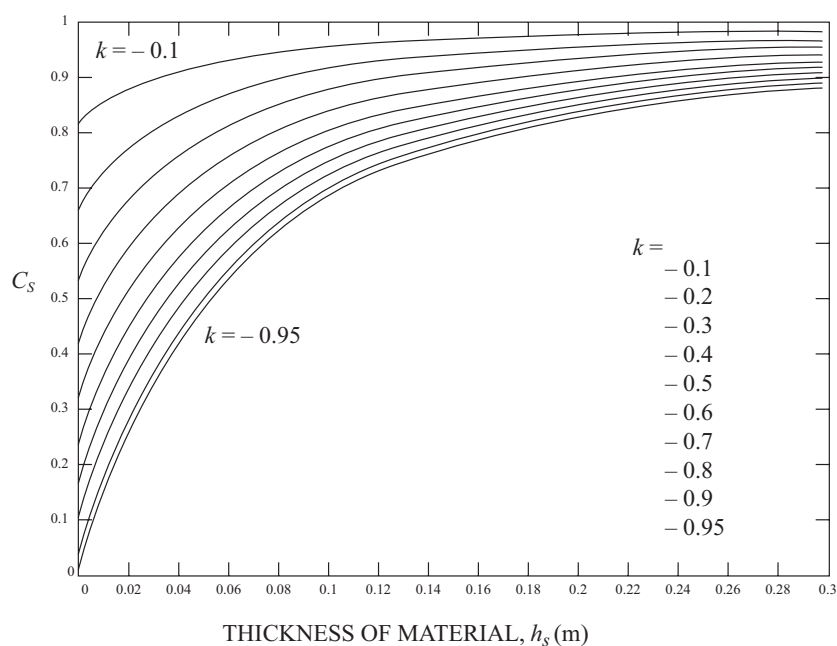

IEEE 80-2013, p. 23, fig. 11, adapted and reprinted with permission from IEEE. Copyright IEEE 2013. All rights reserved.

where

C_s = surface layer derating factor

ρ_s = resistivity of the surface material ($\Omega\cdot\text{m}$)

t_s = duration of shock current (s)

h_s = thickness of the surface layer

ρ = resistivity of the earth beneath the surface material ($\Omega\cdot\text{m}$)

k = reflection factor between different material resistivities

2.2.6.3 Touch Voltage

The maximum allowable touch voltage is given by:

$$E_{\text{touch}_{50}} = (1000 + 1.5C_s(h_s, K)\rho_s)0.116/\sqrt{t_s}$$

$$E_{\text{touch}_{70}} = (1000 + 1.5C_s(h_s, K)\rho_s)0.157/\sqrt{t_s}$$

2.2.6.4 Substation Grounding Resistance

For grounding grid depth less than 0.25 m, the minimum value of substation grounding resistance in uniform soil can be given by:

$$R_g = \frac{\rho}{4}\sqrt{\frac{\pi}{A}}$$

and the upper limit of the substation grounding resistance can be obtained by:

$$R_g = \frac{\rho}{4}\sqrt{\frac{\pi}{A}} + \frac{\rho}{L}$$

where

R_g = station ground resistance (Ω)

ρ = average earth resistivity ($\Omega\cdot\text{m}$)

A = area occupied by the ground grid (m^2)

L = total buried length of conductors (m)

For grid depths between 0.25 and 2.5 m, the substation grounding grid resistance can be approximated by:

$$R_g = \rho \left[\frac{1}{L} + \frac{1}{\sqrt{20A}} \left(1 + \frac{1}{1 + h\sqrt{20/A}} \right) \right]$$

where h is the depth of the grid.

2.2.6.5 Schwarz's Formula

Schwarz's formula gives the total resistance of a system consisting of a combination of horizontal grid and vertical rods.

$$R_g = \frac{R_1 R_2 - R_{12}^2}{R_1 + R_2 - 2R_{12}}$$

where

R_1 = resistance of grid conductors

R_2 = resistance of all ground rods

R_{12} = mutual resistance between the group grid conductors and the group of grounding rods

$$R_1 = (\rho_1/\pi l_1) \left(\ln(2l_1/h) + K_1(l_1/\sqrt{A}) - K_2 \right)$$

$$R_2 = (\rho_a/2n\pi l_2) \left[\ln(8l_2/d_2) - 1 + 2K_1(l_2/\sqrt{A})(\sqrt{n} - 1) \right]$$

$$R_{12} = (\rho_d/\pi l_1) \left(\ln(2l_1/l_2) + K_1(l_1/\sqrt{A}) - K_2 + 1 \right)$$

where

ρ_1 = soil resistivity seen by grid conductors buried at depth h ($\Omega \cdot \text{m}$)

ρ_a = apparent soil resistivity seen by a ground rod buried at depth h ($\Omega \cdot \text{m}$)

H = thickness of the upper layer soil (m)

ρ_2 = soil resistivity from depth H downward ($\Omega \cdot \text{m}$)

l_1 = total length of grid conductors (m)

l_2 = average length of a ground rod (m)

h = buried depth of grid conductors (m)

h' = $\sqrt{d_1 h}$ for conductors buried at depth h or $0.5d_1$ for conductors at $h = 0$ (on ground surface)

A = area covered by a grid of dimensions $a \cdot b$ (m^2)

n = number of ground rods placed in an area A

K_1, K_2 = constants related to the geometry of the system (Figures A and B)

d_1 = diameter of the grid conductor (m)

d_2 = diameter of ground rods (m)

a = short side grid length (m)

b = long side length (m)

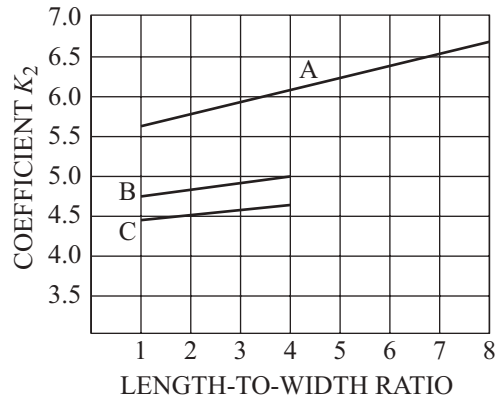

Curve A—for depth $h = 0$

$$Y_A = 0.15X + 5.50$$

Curve B—for depth $h = 1/10 \sqrt{\text{area}}$

$$Y_B = 0.10X + 4.68$$

Curve C—for depth $h = 1/6 \sqrt{\text{area}}$

$$Y_C = -0.05X + 4.40$$

Figure A

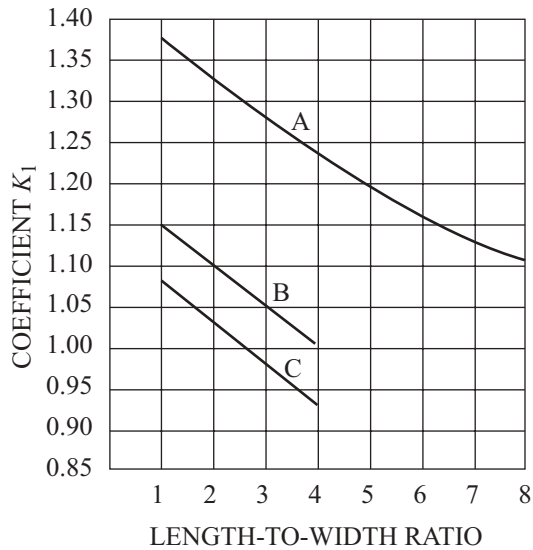

Curve A—for depth $h = 0$

$$Y_A = -0.04X + 1.41$$

Curve B—for depth $h = 1/10 \sqrt{\text{area}}$

$$Y_B = -0.05X + 1.20$$

Curve C—for depth $h = 1/6 \sqrt{\text{area}}$

$$Y_C = -0.05X + 1.13$$

Figure B

IEEE 80-2013, p. 69, fig. 24, adapted and reprinted with permission from IEEE. Copyright IEEE 2013. All rights reserved.

Resistance of a single ground rod is given by:

$$R_{\text{rod}} = \frac{\rho}{2\pi l} [\ln(8l/d) - 1]$$

The effective resistance of a vertical rod encased in concrete is given by:

$$R_{CE\text{-rod}} = \frac{1}{2\pi l} (\rho_c [\ln(D/d)] + \rho [\ln(8l/D) - 1])$$

where

ρ_c = resistivity of concrete ($\Omega \cdot \text{m}$)

ρ = resistivity of soil ($\Omega \cdot \text{m}$)

l = length of ground rod (m)

d = diameter of ground rod (m)

D = diameter of concrete shell (m)

2.3 Codes and Standards

- National Electrical Code (NFPA 70)
- National Electric Safety Code (ANSI C2)
- Standard for Electrical Safety in the Workplace (NFPA 70E)
- Hazardous Area Classification (NFPA 30B, NFPA 497, NFPA 499)

3 CIRCUITS

3.1 Analysis

3.1.1 3-Phase Circuits

The 3-phase line and phase relations are:

$$\begin{array}{ll} \textit{for a delta} & \textit{for a wye} \\ V_L = V_P & V_L = \sqrt{3} V_P = \sqrt{3} V_{LN} \\ I_L = \sqrt{3} I_P & I_L = I_P \end{array}$$

where subscripts L and P denote line and phase, respectively.

The following formulas can be used to determine 3-phase power for balanced systems:

$$\begin{aligned} \mathbf{S} &= P + jQ \\ |\mathbf{S}| &= 3V_P I_P = \sqrt{3} V_L I_L \\ \mathbf{S} &= 3V_P I_P^* = \sqrt{3} V_L I_L (\cos \theta_P + j \sin \theta_P) \end{aligned}$$

where

- \mathbf{S} = total 3-phase complex power (VA)
- $|\mathbf{S}|$ = total 3-phase apparent power (VA)
- P = total 3-phase real, or active, power (W)
- Q = total 3-phase reactive power (var)
- θ_P = power factor angle of each phase
- V_L = rms value of the line-to-line voltage
- V_{LN} = rms value of the line-to-neutral voltage
- I_L = rms value of the line current
- I_P = rms value of the phase current

For a 3-phase, wye-connected source or load with line-to-neutral voltages and a positive (abc) phase sequence:

$$\begin{aligned} V_{an} &= V_P \angle 0^\circ \\ V_{bn} &= V_P \angle -120^\circ \\ V_{cn} &= V_P \angle 120^\circ \end{aligned}$$

The corresponding line-to-line voltages are:

$$\begin{aligned} V_{ab} &= \sqrt{3} V_P \angle 30^\circ \\ V_{bc} &= \sqrt{3} V_P \angle -90^\circ \\ V_{ca} &= \sqrt{3} V_P \angle 150^\circ \end{aligned}$$

Loads may be converted between equivalent delta and wye connections per the following relationships:

$$Z_A = \frac{Z_1 Z_2 + Z_1 Z_3 + Z_2 Z_3}{Z_3}$$

$$Z_B = \frac{Z_1 Z_2 + Z_1 Z_3 + Z_2 Z_3}{Z_1}$$

$$Z_C = \frac{Z_1 Z_2 + Z_1 Z_3 + Z_2 Z_3}{Z_2}$$

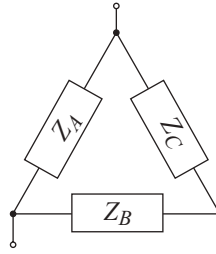

$$Z_1 = \frac{Z_A Z_C}{Z_A + Z_B + Z_C}$$

$$Z_2 = \frac{Z_A Z_B}{Z_A + Z_B + Z_C}$$

$$Z_3 = \frac{Z_B Z_C}{Z_A + Z_B + Z_C}$$

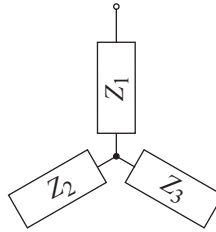

3.1.2 Symmetrical Components

A set of 3-phase unsymmetrical phasors can be resolved into a set of 3-phase symmetrical phasors by the following transformation:

$$\begin{bmatrix} V_{a0} \\ V_{a1} \\ V_{a2} \end{bmatrix} = \frac{1}{3} \begin{bmatrix} 1 & 1 & 1 \\ 1 & a & a^2 \\ 1 & a^2 & a \end{bmatrix} \begin{bmatrix} V_a \\ V_b \\ V_c \end{bmatrix}$$

where subscripts 0, 1 and 2 denote the zero, positive (abc) and negative (acb) sequence components, respectively, and the operator a is $1\angle 120^\circ = -0.5 + j0.866$.

Likewise, a set of 3-phase unsymmetrical phasors can be constructed from a set of 3-phase symmetrical phasors by the following transformation:

$$\begin{bmatrix} V_a \\ V_b \\ V_c \end{bmatrix} = \begin{bmatrix} 1 & 1 & 1 \\ 1 & a^2 & a \\ 1 & a & a^2 \end{bmatrix} \begin{bmatrix} V_{a0} \\ V_{a1} \\ V_{a2} \end{bmatrix}$$

3.1.3 Per Unit System

For single-phase systems,

$$\text{Base Current, A} = \frac{\text{Base } kVA_{1\phi}}{\text{Base Voltage, } kV_{LN}}$$

$$\begin{aligned} \text{Base Impedance, } \Omega &= \frac{\text{Base Voltage, } kV_{LN}}{\text{Base Current, } A} \\ &= \frac{(\text{Base Voltage, } kV_{LN})^2}{\text{Base MVA}_{1\phi}} \end{aligned}$$

For 3-phase systems,

$$\text{Base Current, A} = \frac{\text{Base } kVA_{3\phi}}{\sqrt{3} \cdot \text{Base Voltage, } kV_{LL}}$$

$$\begin{aligned} \text{Base Impedance, } \Omega &= \frac{\text{Base Voltage, } kV_{LN}}{\text{Base Current, } A} \\ &= \frac{(\text{Base Voltage, } kV_{LL})^2}{\text{Base MVA}_{3\phi}} \end{aligned}$$

The following equation may be used to change a per-unit impedance from an old base to a new base:

$$Z_{\text{new}} = Z_{\text{old}} \cdot \left(\frac{\text{Base } kV_{\text{old}}}{\text{Base } kV_{\text{new}}} \right)^2 \cdot \left(\frac{\text{Base } kVA_{\text{new}}}{\text{Base } kVA_{\text{old}}} \right)$$

3.1.4 Single-Phase Circuits

3.1.4.1 AC Circuits

For a sinusoidal voltage or current of frequency f (Hz) and period T (seconds),

$$f = 1/T = \omega/(2\pi)$$

where

$$\omega = \text{angular frequency (radians/s)}$$

Average Value

For a periodic waveform (either voltage or current) with period T ,

$$X_{\text{ave}} = (1/T) \int_0^T x(t) dt$$

The average value of a full-wave rectified sinusoid is:

$$X_{\text{ave}} = (2X_{\text{max}})/\pi$$

and half this for half-wave rectification

where

$$X_{\text{max}} = \text{peak amplitude of the sinusoid}$$

Effective or RMS Values

For a periodic waveform with period T , the rms or effective value is:

$$X_{\text{eff}} = X_{\text{rms}} = \left[(1/T) \int_0^T x^2(t) dt \right]^{1/2}$$

For a sinusoidal waveform and full-wave rectified sine wave,

$$X_{\text{eff}} = X_{\text{rms}} = X_{\text{max}}/\sqrt{2}$$

For a half-wave rectified sine wave,

$$X_{\text{eff}} = X_{\text{rms}} = X_{\text{max}}/2$$

For a periodic signal,

$$X_{\text{rms}} = \sqrt{X_{\text{dc}}^2 + \sum_{n=1}^{\infty} X_n^2}$$

where

$$X_{\text{dc}} = \text{dc component of } x(t)$$

$$X_n = \text{rms value of the } n\text{th harmonic}$$

Sine-Cosine Relations and Trigonometric Identities

$$\cos(\omega t) = \sin(\omega t + \pi/2) = -\sin(\omega t - \pi/2)$$

$$\sin(\omega t) = \cos(\omega t - \pi/2) = -\cos(\omega t + \pi/2)$$

Other trigonometric identities for sinusoids are given in the section on [Trigonometry](#).

Phasor Transforms of Sinusoids

$$P[V_{\max} \cos(\omega t + \phi)] = V_{\text{rms}} \angle \phi = \mathbf{V}$$

$$P[I_{\max} \cos(\omega t + \theta)] = I_{\text{rms}} \angle \theta = \mathbf{I}$$

For a circuit element, the impedance is defined as the ratio of phasor voltage to phasor current.

$$\mathbf{Z} = \mathbf{V}/\mathbf{I}$$

For a resistor, $\mathbf{Z}_R = R$

For a capacitor, $\mathbf{Z}_C = \frac{1}{j\omega C} = jX_C$

For an inductor, $\mathbf{Z}_L = j\omega L = jX_L$

where

X_C and X_L are the capacitive and inductive reactances, respectively, defined as:

$$X_C = -\frac{1}{\omega C}$$

$$X_L = \omega L$$

Complex Power

Real power P (watts) is defined by:

$$P = \frac{1}{2} V_{\max} I_{\max} \cos \theta$$

$$= V_{\text{rms}} I_{\text{rms}} \cos \theta$$

where θ is the angle measured from \mathbf{V} to \mathbf{I} . If \mathbf{I} leads (lags) \mathbf{V} , then the power factor pf ,

$$pf = \cos \theta$$

is said to be a leading (lagging) pf .

Reactive power Q (vars) is defined by

$$Q = \frac{1}{2} V_{\max} I_{\max} \sin \theta$$

$$= V_{\text{rms}} I_{\text{rms}} \sin \theta$$

Complex power \mathbf{S} (volt-amperes) is defined by

$$\mathbf{S} = \mathbf{VI}^* = P + jQ$$

where \mathbf{I}^* is the complex conjugate of the phasor current.

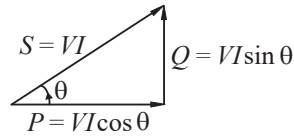

Complex Power Triangle (Inductive Load)

3.1.5 DC Circuits

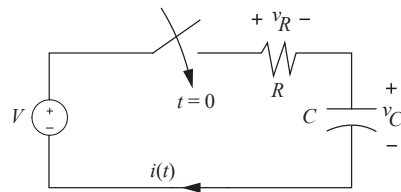

$$t \geq 0; v_C(t) = v_C(0)e^{-t/RC} + V(1 - e^{-t/RC})$$

$$i(t) = \{[V - v_C(0)]/R\}e^{-t/RC}$$

$$v_R(t) = i(t)R = [V - v_C(0)]e^{-t/RC}$$

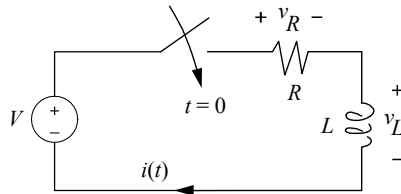

$$t \geq 0; i(t) = i(0)e^{-Rt/L} + \frac{V}{R}(1 - e^{-Rt/L})$$

$$v_R(t) = i(t)R = i(0)Re^{-Rt/L} + V(1 - e^{-Rt/L})$$

$$v_L(t) = L(di/dt) = -i(0)Re^{-Rt/L} + Ve^{-Rt/L}$$

where $v(0)$ and $i(0)$ denote the initial conditions and the parameters RC and L/R are termed the respective circuit time constants.

3.1.6 Single-Line Diagrams

The following table lists device number designations according to ANSI/IEEE C37.2 for common power system elements.

Device #	Function	Device #	Function
21	Distance Relay	52	Circuit Breaker
25	Synchronizing or Sync-Check Device	59	Overvoltage Relay
27	Undervoltage Relay	67	AC Directional Overcurrent Relay
32	Directional or Reverse Power Relay	79	Reclosing Relay
43	Manual Transfer or Selector Device	81	Frequency Relay
50	Instantaneous Overcurrent Relay	86	Lockout Relay/Master Trip Device
51	Inverse Time Overcurrent Relay	87	Differential Relay
SUFFIX	DEFINITION		
B	Bus	CC	Closing Coil
G	Ground	TC	Trip Coil
L	Line		
P	Phase		
T	Transformer		
N	Neutral		

3.2 Devices and Power Electronic Circuits

3.2.1 Battery Characteristics and Ratings

3.2.1.1 Voltage, Capacity, and Specific Energy of Major Battery Systems—Theoretical and Practical Values

Voltage, Capacity, and Specific Energy of Major Battery Systems—Theoretical and Practical Values

Battery type	Anode	Cathode	Reaction mechanism	Theoretical values ^a			Practical battery ^b				
				V	g/Ah	Ah/kg	Specific energy Wh/kg	Nominal voltage V	Specific energy Wh/kg	Energy density Wh/L	
Primary batteries											
Leclanché	Zn	MnO ₂	Zn + 2MnO ₂ → ZnO • Mn ₂ O ₃	1.6	4.46	224	358	1.5	85 ^f	165 ^f	
Magnesium	Mg	MnO ₂	Mg + 2 MnO ₂ + H ₂ O → Mn ₂ O ₃ + Mg(OH) ₂	2.8	3.69	271	759	1.7	100 ^f	195 ^f	
Alkaline MnO ₂	Zn	MnO ₂	Zn + 2MnO ₂ → ZnO + Mn ₂ O ₃	1.5	4.46	224	358	1.5	154 ^f	461 ^f	
Mercury	Zn	HgO	Zn + HgO → ZnO + Hg	1.34	5.27	190	255	1.35	100 ^h	470 ^h	
Mercad	Cd	HgO	Cd + HgO + H ₂ O → Cd(OH) ₂ + Hg	0.91	6.15	163	148	0.9	55 ^h	230 ^h	
Silver oxide	Zn	Ag ₂ O	Zn + Ag ₂ O + H ₂ O → Zn(OH) ₂ + 2Ag	1.6	5.55	180	288	1.6	135 ^h	525 ^h	
Zinc-O ₂	Zn	O ₂	Zn + (1/2 O ₂) → ZnO	1.65	1.52	658	1085	—	—	—	
Zinc-air	Zn	Ambient air	Zn + (1/2 O ₂) → ZnO	1.65	1.22	820	1353	1.5	415 ^h	1350 ^h	
Li-SOCl ₂	Li	SOCl ₂	4Li + 2SOCl ₂ → 4LiCl + S + SO ₂	3.65	3.25	403	1471	3.6	590 ^f	1100 ^f	
Li-SO ₂	Li	SO ₂	2Li + 2SO ₂ → Li ₂ S ₂ O ₄	3.1	2.64	379	1175	3.0	260 ^g	415 ^g	
LiMnO ₂	Li	MnO ₂	Li + Mn ^{IV} O ₂ → Mn ^{IV} O ₂ (Li ⁺)	3.5	3.50	286	1001	3.0	260 ^g	546 ^g	
Li-FeS ₂	Li	FeS ₂	4Li + FeS ₂ → 2Li ₂ S + Fe	1.8	1.38	726	1307	1.5	310 ^g	560 ^g	
Li-CF _x	Li	CF _x	xLi + CF _x → xLiF + xC	3.1	1.42	706	2189	3.0	360 ^g	540 ^g	
Li-I ₂ ^e	Li	I ₂ (P2VP)	Li + 1/2 I ₂ → LiI	2.8	4.99	200	560	2.8	245	900	
Reserve batteries											
Cuprous chloride	Mg	CuCl	Mg + Cu ₂ Cl ₂ → MgCl ₂ + 2Cu	1.6	4.14	241	386	1.3	60 ⁱ	80 ⁱ	
Zinc-silver oxide	Zn	AgO	Zn + AgO + H ₂ O → Zn(OH) ₂ + Hg	1.81	3.53	283	512	1.5	30 ^j	75 ^j	
Thermal ^d	Li	FeS ₂		2.1–1.6	1.38	726	1307	2.1–1.6	40 ^k	100 ^k	

Voltage, Capacity, and Specific Energy of Major Battery Systems—Theoretical and Practical Values (continued)

Battery type	Anode	Cathode	Reaction mechanism	Theoretical values ^a			Practical battery ^b			
				V	g/Ah	Ah/kg	Specific energy Wh/kg	Nominal voltage V	Specific energy Wh/kg	Energy density Wh/L
Secondary batteries										
Lead-acid	Pb	PbO ₂	Pb + PbO ₂ + 2H ₂ SO ₄ → 2PbSO ₄ + 2H ₂ O	2.1	8.32	120	252	2.0	35	70 ^l
Edison	Fe	Ni oxide	Fe + 2NiOOH + 2H ₂ O → 2Ni(OH) ₂ + Fe(OH) ₂	1.4	4.46	224	314	1.2	30	55 ^l
Nickel-cadmium	Cd	Ni oxide	Cd + 2NiOOH + 2H ₂ O → 2Ni(OH) ₂ + Cd(OH) ₂	1.35	5.52	181	244	1.2	40	135 ^g
Nickel-zinc	Zn	Ni oxide	Zn + 2NiOOH + 2H ₂ O → 2Ni(OH) ₂ + Zn(OH) ₂	1.73	4.64	215	372	1.6	90	185
Nickel-hydrogen	H ₂	Ni oxide	H ₂ + 2NiOOH → 2Ni(OH) ₂	1.5	3.46	289	434	1.2	55	60
Nickel-metal hydride	MH ^c	Ni oxide	MH + NiOOH → M + Ni(OH) ₂	1.35	5.63	178	240	1.2	100	235 ^g
Silver-zinc	Zn	AgO	Zn + AgO + H ₂ O → Zn(OH) ₂ + Ag	1.85	3.53	283	524	1.5	105	180 ^l
Silver-cadmium	Cd	AgO	Cd + AgO + H ₂ O → Cd(OH) ₂ + Ag	1.4	4.41	227	318	1.1	70	120 ^l
Zinc-chlorine	Zn	Cl ₂	Zn + Cl ₂ → ZnCl ₂	2.12	2.54	394	835	—	—	—
Zinc-bromine	Zn	Br ₂	Zn + Br ₂ → ZnBr ₂	1.85	4.17	309	572	1.6	70	60
Lithium-ion	Li _x C ₆	Li _(1-x) CoO ₂	Li _x C ₆ + Li _(1-x) CoO ₂ → LiCoO ₂ + C ₆	4.1	9.14	109	448	3.8	200	570 ^g
Lithium-manganese dioxide	Li	MnO ₂	Li + Mn ^{IV} O ₂ → Mn ^{IV} O ₂ (Li ⁺)	3.5	3.50	286	1001	3.0	120	265
Lithium-iron disulfide ^d	Li(Al)	FeS ₂	2Li(Al) + FeS ₂ → Li ₂ FeS ₂ + 2Al	1.73	3.50	285	493	1.7	180 ^m	350 ^m
Sodium-sulfur ^d	Na	S	2Na + 3S → Na ₂ S ₃	2.1	2.65	377	792	2.0	170 ^m	345 ^m
Sodium-nickel chloride ^d	Na	NiCl ₂	2Na + NiCl ₂ → 2NaCl + Ni	2.58	3.28	305	787	2.6	115 ^m	190 ^m
Fuel cells										
H ₂ -O ₂	H ₂	O ₂	H ₂ + 1/2 O ₂ → H ₂ O	1.23	0.336	2975	3660			
H ₂ -air	H ₂	Ambient air	H ₂ + (1/2 O ₂) → H ₂ O	1.23	0.037	26587	32702			
Methanol-O ₂	CH ₃ OH	O ₂	CH ₃ OH + 3/2 O ₂ → CO ₂ + 2H ₂ O	1.24	0.50	2000	2480	—	—	—
Methanol-air	CH ₃ OH	Ambient air	CH ₃ OH + (3/2 O ₂) → CO ₂ + 2H ₂ O	1.24	0.20	5020	6225	—	—	—

^a Based on active anode and cathode materials only, including O₂ but not air (electrolyte not included).
^b These values are for single-cell batteries based on identified design and at discharge rates optimized for energy density, using midpoint voltage.
^c MH = metal hydride, data based on type AB₃ alloy.
^d High-temperature batteries.
^e Solid electrolyte batteries (Li/I₂ (P2VP)).
^f Cylindrical bobbin-type batteries.
^g Cylindrical spiral-wound batteries.
^h Button-type batteries.
ⁱ Water-activated.
^j Automatically activated 2- to 10 min-rate.
^k With lithium anodes.
^l Prismatic batteries.
^m Value based on cell performance.

3.2.1.2 Standard Potential of a Cell

$$E^0 = V_{\text{cathode}} - V_{\text{anode}}$$

3.2.1.3 Theoretical Capacity of a Cell

$$C_{\text{cell}} = \frac{1}{\frac{1}{EC_a} + \frac{1}{EC_c}}$$

where

EC_a = electrochemical equivalent of the anode

EC_c = electrochemical equivalent of the cathode

3.2.1.4 Characteristics of Typical Electrode Materials

Characteristics of Typical Electrode Materials

Material	Atomic or molecular weight, g	Standard reduction potential at 25°C, V	Valence change	Melting point, °C	Density, g/cm ³	Electrochemical equivalents		
						Ah/g	g/Ah	Ah/cm ³
Anode materials								
H ₂	2.01	0 -0.83	2	—	—	26.59	0.037	—
Li	6.94	-3.01	1	180	0.54	3.86	0.259	2.06
Na	23.0	-2.71	1	98	0.97	1.16	0.858	1.14
Mg	24.3	-2.38 -2.69	2	650	1.74	2.20	0.454	3.8
Al	26.9	-1.66	3	659	2.69	2.98	0.335	8.1
Ca	40.1	-2.84 -2.35	2	851	1.54	1.34	0.748	2.06
Fe	55.8	-0.44 -0.88	2	1528	7.85	0.96	1.04	7.5
Zn	65.4	-0.76 -1.25	2	419	7.14	0.82	1.22	5.8
Cd	112.4	-0.40 -0.81	2	321	8.65	0.48	2.10	4.1
Pb	207.2	-0.13	2	327	11.34	0.26	3.87	2.9
(Li)C ₆	72.06	~ -2.8	1	—	2.25	0.372	2.69	0.837
MH		-0.83	2	—	—	0.305	3.28	—
CH ₃ OH	32.04	—	6	—	—	5.02	0.20	—
Cathode materials								
CuF ₂	101.5	3.55	2	—	—	0.528	1.89	—
O ₂	32.0	1.23 0.40	4	—	—	3.35	0.30	—
Cl ₂	71.0	1.36	2	—	—	0.756	1.32	—
SO ₂	64.0	—	1	—	—	0.419	2.38	—
MnO ₂	86.9	1.28	1	—	5.0	0.308	3.24	1.54
NiOOH	91.7	0.49	1	—	7.4	0.292	3.42	2.16
CuCl	99.0	0.14	1	—	3.5	0.270	3.69	0.95
FeS ₂	119.9	—	4	—	—	0.89	1.12	4.35
AgO	123.8	0.57	2	—	7.4	0.432	2.31	3.20
Br ₂	159.8	1.07	2	—	—	0.335	2.98	—
HgO	216.6	0.10	2	—	11.1	0.247	4.05	2.74
Ag ₂ O	231.7	0.35	2	—	7.1	0.231	4.33	1.64
PbO ₂	239.2	1.69	2	—	9.4	0.224	4.45	2.11
LiFePO ₄	163.8	~0.42	1	—	3.44	0.160	6.25	0.554
LiMn ₂ O ₄ (spinel)	148.8	~1.2	1	—	4.1	0.120	8.33	0.492
Li _x CoO ₂	98	~1.25	0.5	—	5.05	0.155	6.45	0.782
I ₂	253.8	0.54	2	—	4.94	0.211	4.73	1.04

Republished with permission of McGraw-Hill, from Reddy, Thomas B., ed., *Linden's Handbook of Batteries*, 4 ed., McGraw Hill, 2011, table 1.1; permission conveyed through Copyright Clearance Center, Inc.

3.2.1.5 Theoretical Energy

$$\text{Energy (Wh)} = \text{Voltage (V)} \cdot \text{Charge (Ah)}$$

3.2.1.6 Discharge Rates

Discharge current relates to a battery's C -rate as follows:

$$I = M \cdot C_n$$

where

I = discharge current (A)

C = rated capacity of the battery (Ah)

n = time (h) for which rated capacity is declared

M = multiple or fraction of C

Likewise, discharge power relates to a battery's E -rate as follows:

$$P = M \cdot E_n$$

where

P = power (W)

E = rated energy of the battery (Wh)

n = time (h) which the battery is rated

M = multiple or fraction of E

3.2.1.7 Relationship of Temperature on Battery Capacity

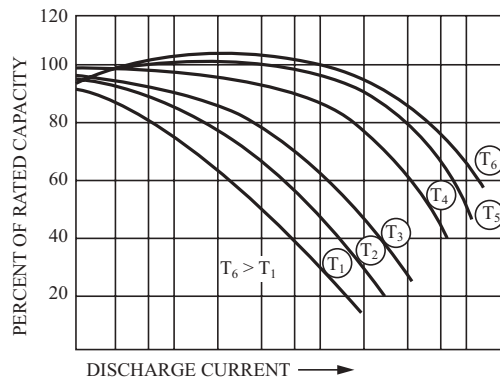

*Effect of discharge load on battery capacity at various temperatures
 T_1 to T_6 —increasing temperatures; T_4 —normal room temperature*

Reprinted with permission of McGraw-Hill, from Reddy, Thomas B., ed., *Linden's Handbook of Batteries*, 4 ed., McGraw Hill, 2011, fig 3.10; permission conveyed through Copyright Clearance Center, Inc.

3.2.1.8 Peukert's Relation for Lead-Acid Batteries

The rate-dependent capacity of a lead-acid battery may be represented Peukert's equation (Wilhelm Peukert, 1897), an empirically determined relationship between battery capacity and discharge rate under constant temperature and constant discharge current conditions:

$$C_p = I^k \cdot t$$

where

C_p = capacity of the battery (Ah) for a constant 1.0 A discharge current

I = actual discharge current (A)

k = Peukert constant (dimensionless)

t = discharge time (h)

Each battery has its own unique Peukert constant, typically in the range of 1.1 to 1.4.

A more useful form of Peukert's equation relates actual discharge time to rated discharge time:

$$t = H \left(\frac{C}{IH} \right)^k$$

where

t = actual discharge time (h) at discharge current I (A)

C = manufacturer-specified nominal battery capacity (Ah) at the manufacturer-specified discharge period H (h)

k = Peukert constant (dimensionless)

3.2.2 Power Supplies and Converters

3.2.2.1 AC-DC Converters

Uncontrolled single-phase half-wave rectifier

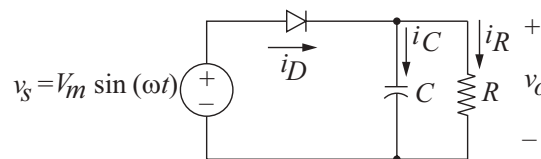
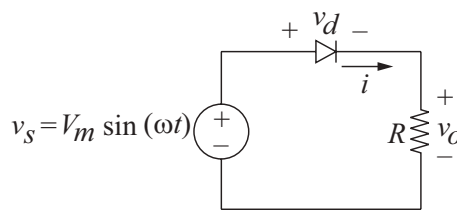

Republished with permission of McGraw-Hill, from Hart, Daniel, *Power Electronics*, McGraw-Hill, 2010, pp. 66, 88; permission conveyed through Copyright Clearance Center, Inc.

$$V_o = V_{\text{avg}} = \frac{1}{2\pi} \int_0^T V_m \sin(\omega t) d(\omega t) = \frac{V_m}{\pi}$$

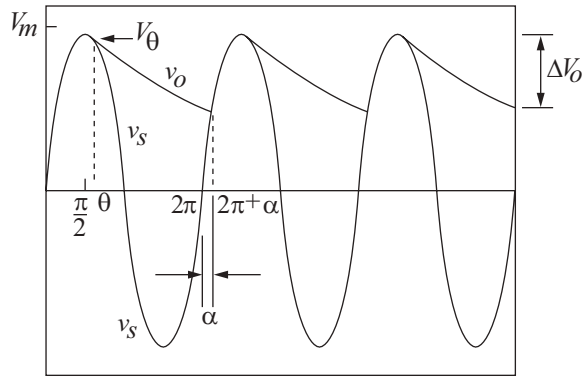

Republished with permission of McGraw-Hill, from Hart, Daniel, *Power Electronics*, McGraw-Hill, 2010, p. 88; permission conveyed through Copyright Clearance Center, Inc.

For small ΔV_o ,

$$\Delta V_o \approx V_m \left(\frac{2\pi}{\omega RC} \right) = \frac{V_m}{fRC}$$

Controlled single-phase half-wave rectifier

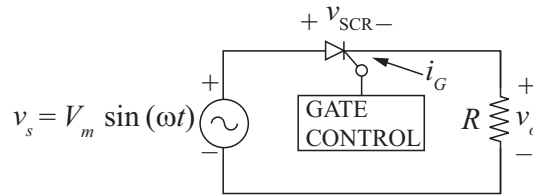

A basic controlled rectifier

$$V_o = \frac{1}{2\pi} \int_{\alpha}^{\pi} V_m \sin(\omega t) d(\omega t) = \frac{V_m}{2\pi} (1 + \cos \alpha)$$

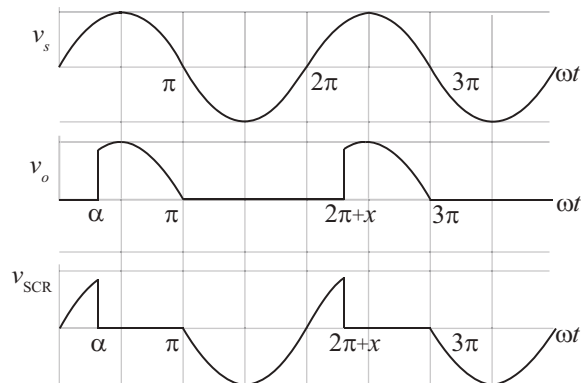

Voltage waveforms

Republished with permission of McGraw-Hill, from Hart, Daniel, *Power Electronics*, McGraw-Hill, 2010, p. 95; permission conveyed through Copyright Clearance Center, Inc. Adapted by NCEES for exam use only.

$$v_o(t) = V_o + \sum_{n=2,4,\dots}^{\infty} V_n \cos(n\omega_0 t + \pi)$$

where $V_o = \frac{2V_m}{\pi}$

and $V_n = \frac{2V_m}{\pi} \left(\frac{1}{n-1} - \frac{1}{n+1} \right)$

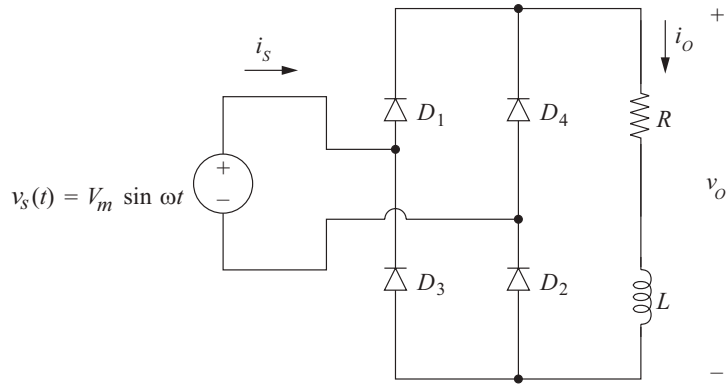

Republished with permission of McGraw-Hill, from Hart, Daniel, *Power Electronics*, McGraw-Hill, 2010, p. 116; permission conveyed through Copyright Clearance Center, Inc.

Controlled single-phase full-wave rectifier

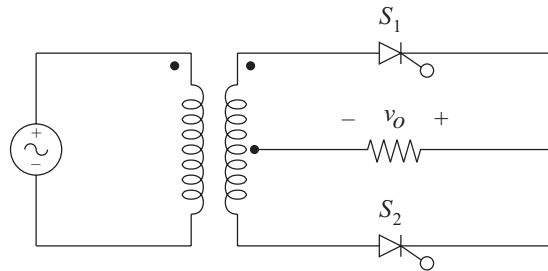
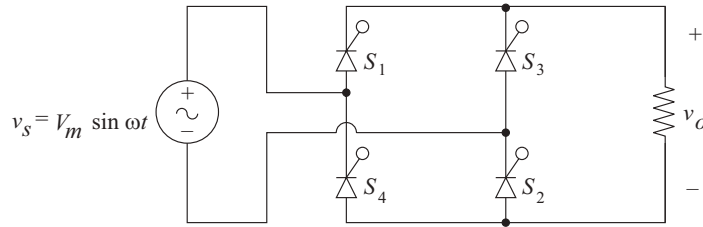

$$V_0 = \frac{1}{\pi} \int_{\alpha}^{\pi} V_m \sin(\omega t) d(\omega t) = \frac{V_m}{\pi} (1 + \cos \alpha)$$

Republished with permission of McGraw-Hill, from Hart, Daniel, *Power Electronics*, McGraw-Hill, 2010, p. 132; permission conveyed through Copyright Clearance Center, Inc.

Uncontrolled 3-phase full-wave rectifier

$$V_0 = \frac{1}{\pi/3} \int_{\pi/3}^{2\pi/3} V_{m,L-L} \sin(\omega t) d(\omega t) = \frac{3V_{m,L-L}}{\pi} = 0.955V_{m,L-L}$$

$$V_n = \frac{6V_{m,L-L}}{\pi(n^2 - 1)} \quad n = 6, 12, 18, \dots$$

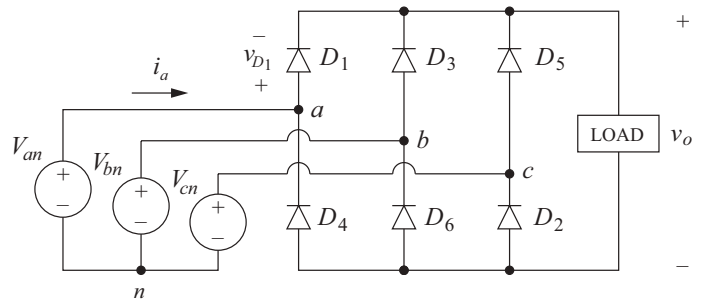

Republished with permission of McGraw-Hill, from Hart, Daniel, *Power Electronics*, McGraw-Hill, 2010, p. 144; permission conveyed through Copyright Clearance Center, Inc.

3.2.2.2 DC-DC Converters

Buck Converter

$$D = \frac{t_{on}}{T}$$

$$V_o = V_s D$$

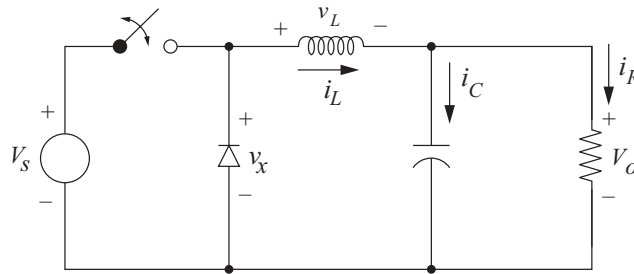

Republished with permission of McGraw-Hill, from Hart, Daniel, *Power Electronics*, McGraw-Hill, 2010, p. 199; permission conveyed through Copyright Clearance Center, Inc.

Boost Converter

$$V_o = \frac{V_s}{1 - D}$$

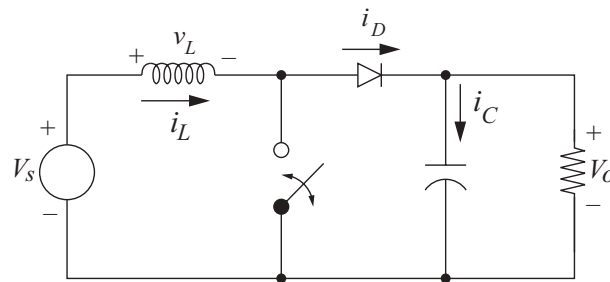

Republished with permission of McGraw-Hill, from Hart, Daniel, *Power Electronics*, McGraw-Hill, 2010, p. 212; permission conveyed through Copyright Clearance Center, Inc.

Buck-Boost Converter

$$V_o = -V_s \left[\frac{D}{1-D} \right]$$

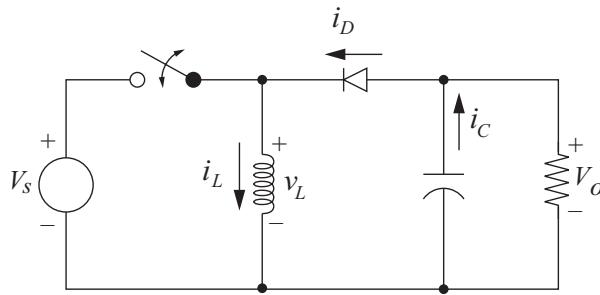

Republished with permission of McGraw-Hill, from Hart, Daniel, *Power Electronics*, McGraw-Hill, 2010, p. 221; permission conveyed through Copyright Clearance Center, Inc.

3.2.2.3 Inverters

Full-bridge inverter with R-L load

$$i_o(t) = \begin{cases} \frac{V_{dc}}{R} + \left(I_{min} - \frac{V_{dc}}{R} \right) e^{-t/\tau} & \text{for } 0 < t < \frac{T}{2} \\ -\frac{V_{dc}}{R} + \left(I_{max} + \frac{V_{dc}}{R} \right) e^{-(t-T/2)/\tau} & \text{for } \frac{T}{2} < t < T \end{cases}$$

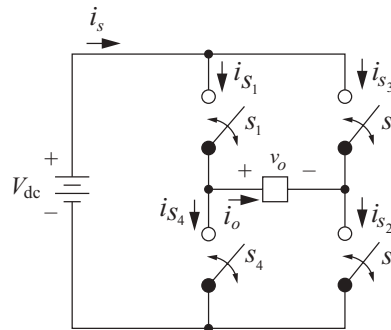

$$I_{max} = -I_{min} = \frac{V_{dc}}{R} \left[\frac{1 - e^{-T/2\tau}}{1 + e^{-T/2\tau}} \right]$$

$$I_{rms} = \sqrt{\frac{1}{T} \int_0^T i^2(t) dt} = \sqrt{\frac{2}{T} \int_0^{T/2} \left[\frac{V_{dc}}{R} + \left(I_{min} - \frac{V_{dc}}{R} \right) e^{-t/\tau} \right]^2 dt}$$

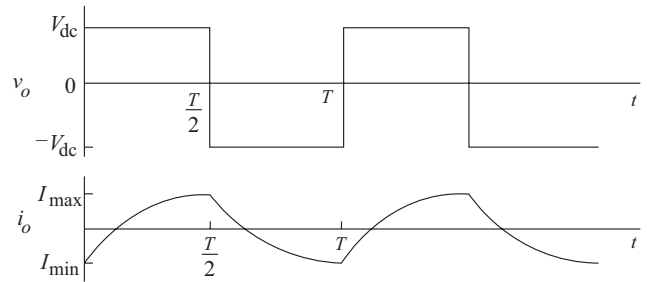

Republished with permission of McGraw-Hill, from Hart, Daniel, *Power Electronics*, McGraw-Hill, 2010, pp. 332 and 334; permission conveyed through Copyright Clearance Center, Inc.

3.2.3 Variable-Speed Drives

Variable-speed drive control methods include (1) scalar control and (2) vector (or field-oriented) control. Scalar control, which is well-suited to variable torque applications such as pump and fan loads, maintains a linear volts-per-hertz (V/f) relationship at the motor terminals between zero and rated motor speed. Vector control involves the regulation of the inverter currents such that independent control of the motor's magnetic flux and torque are achieved. This allows for rated torque to be developed anywhere between zero and rated motor speed. Both methods allow for operation above rated motor speed through "field weakening," where the inverter frequency is increased linearly with speed while maintaining a constant terminal voltage magnitude.

4 ROTATING MACHINES AND ELECTRIC POWER DEVICES

Common nomenclature

E = line-to-neutral terminal voltage

P = power

T = torque

n = speed

n_s = synchronous speed

f = frequency

p = number of machine poles

Subscripts

e = electrical

m = mechanical

fl = full load

nl = no load

4.1 Synchronous Machines

Synchronous machine nomenclature

E_0 = line-to-neutral internally induced stator voltage

E_x = line-to-neutral armature reaction voltage

X_s = synchronous reactance

I_x = field current

X_d = direct-axis synchronous reactance

X_q = quadrature-axis synchronous reactance

X_{ds} = unsaturated direct-axis synchronous reactance

X'_d = direct-axis transient reactance

X'_q = quadrature-axis transient reactance

X''_d = direct-axis subtransient reactance

X''_q = quadrature-axis subtransient reactance

δ = torque angle (angle of E_0 with respect to E)

4.1.1 Generator and Motor Applications

4.1.1.1 Power, Torque, and Speed Relationships

When T is in N•m and n is in rpm, P in kW is:

$$P(\text{kW}) = T(\text{N}\cdot\text{m}) \cdot n(\text{rpm})/9549$$

4.1.1.2 Synchronous Speed

When n_s is in rpm and f is in Hz:

$$n_s = \frac{120f}{p}$$

4.1.1.3 Governor Control for Synchronous Generators

With speed-governor control in place, the generator speed droop, in percent, is given by:

$$\text{Speed Droop \%} = \frac{n_{nl} - n_{fl}}{n_{fl}} \cdot 100$$

The steady-state governor response changes the generator output power as a linear function of frequency deviation according to the following:

$$\Delta P = m_p (f_{\text{nominal}} - f_{\text{actual}})$$

where m_p is the governor droop response in MW/Hz.

4.1.2 Equivalent Circuits and Characteristics

Synchronous machine equivalent circuit

The steady-state characteristics of a lossless wound-field excited synchronous machine may be determined via the equivalent circuit in the figure below.

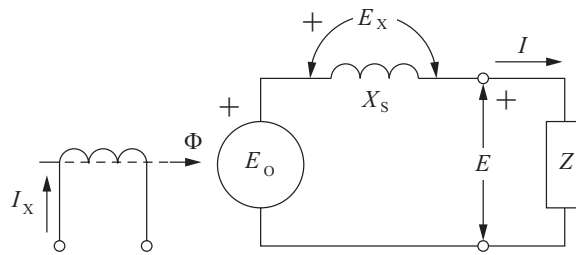

Wildi, Theodore, *Electrical Machines, Drives, and Power Systems*, 6 ed., Pearson, 2005, p. 356.

The corresponding phasor diagram for synchronous generator supplying a lagging power factor load Z is:

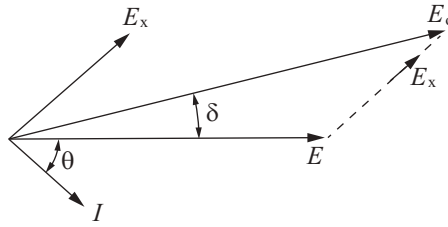

Wildi, Theodore, *Electrical Machines, Drives, and Power Systems*, 6 ed., Pearson, 2005, p. 359.

4.1.3 Motor Starting

Synchronous motors are not inherently self-starting when connected to a fixed-frequency supply. They must be brought up to synchronous speed either by external mechanical means or by bypassing the exciter and using the shorted field and damper windings to act as induction motor rotor windings until the rotor nears synchronous speed.

4.1.4 Electrical Machine Theory

Synchronous machine theory

The unsaturated direct-axis synchronous reactance per-phase (neglecting the small stator resistance) can be obtained from the machine's open-circuit and short-circuits tests and characteristics.

$$X_{ds} = \frac{V_{oc}}{I_{sc}}$$

where

V_{oc} = rated open-circuit line-to-neutral voltage from air-gap characteristic

I_{sc} = short-circuit current per phase, using the same excitation current required to produce V_{oc}

The unsaturated short-circuit ratio (*SCR*) is the inverse of the per-unit unsaturated direct-axis synchronous reactance.

$$SCR = \frac{1}{X_{ds(pu)}}$$

The steady-state electrical power P_e delivered to or from a lossless 3-phase synchronous machine is:

$$P_e = \frac{3E_0E}{X_s} \sin(\delta) \quad (\text{cylindrical rotor})$$

$$P_e = \frac{3E_0E}{X_d} \sin(\delta) + \frac{3E^2(X_d - X_q)}{2X_dX_q} \sin(2\delta) \quad (\text{salient-pole rotor})$$

The synchronizing power per electrical radian P_{sync} for a lossless 3-phase synchronous machine may be obtained by differentiating P_e with respect to δ :

$$P_{sync} = \frac{3E_0E}{X_s} \cos(\delta) \quad (\text{cylindrical rotor})$$

$$P_{sync} = \frac{3E_0E}{X_d} \cos(\delta) + \frac{3E^2(X_d - X_q)}{X_dX_q} \cos(2\delta) \quad (\text{salient-pole rotor})$$

The steady-state electromagnetic torque T_e for a lossless 3-phase synchronous machine may be obtained by dividing P_e by n_s :

$$T_e = \frac{3E_0E}{X_s n_s} \sin(\delta) \quad (\text{cylindrical rotor})$$

$$T_e = \frac{3E_0E}{X_d n_s} \sin(\delta) + \frac{3E^2(X_d - X_q)}{2X_d X_q n_s} \sin(2\delta) \quad (\text{salient-pole rotor})$$

where n_s is the rotor speed in radians/second.

4.2 Induction Machines

Induction machine nomenclature

s = percent slip

R_1 = stator resistance

X_1 = stator leakage reactance

R_2 = rotor resistance (referred to stator)

X_2 = stator leakage reactance (referred to stator)

R_C = core loss resistance

X_M = magnetizing reactance

4.2.1 Generator and Motor Applications

4.2.1.1 Power, Torque, and Speed Relationships

When T is in N•m and n is in rpm, P in kW is:

$$P(\text{kW}) = T(\text{N}\cdot\text{m}) \cdot n(\text{rpm})/9549$$

4.2.1.2 Synchronous Speed

When n_s is in rpm and f is in Hz:

$$n_s = \frac{120f}{p}$$

4.2.1.3 Percent Slip in Induction Machines

$$s = \frac{n_s - n}{n_s} \cdot 100$$

4.2.1.4 Speed Control for Induction Machines

Four common methods of speed control for induction machines include:

1. Pole Changing. The machine is equipped with multiple stator windings, and its synchronous speed is changed by switching between windings to create a different pole count.
2. Line Frequency Changing. The synchronous speed is changed by changing the supply frequency at constant terminal voltage.
3. Slip Variation. The machine's torque-speed curve is changed by varying the rotor resistance as shown in the figure below. This method applies only to wound-rotor machines that provide access to the rotor windings.

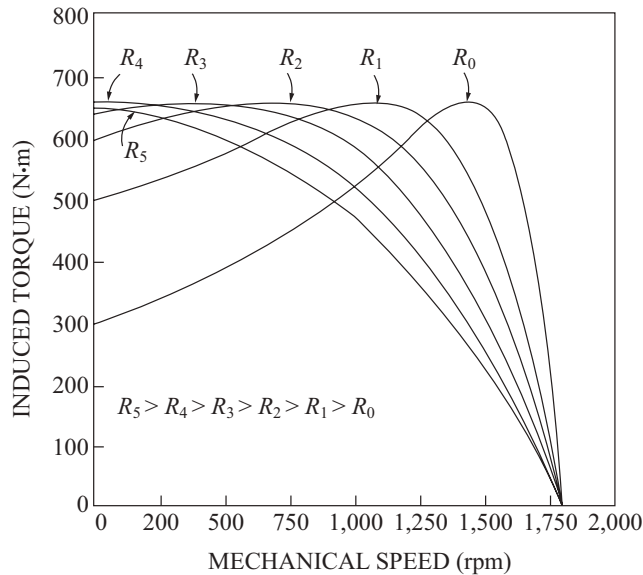

Torque-speed characteristics with varying rotor resistance

Republished with permission of McGraw-Hill, from Chapman, Stephen, *Electric Machines and Power System Fundamentals*, McGraw-Hill, 2001, p. 412; permission conveyed through Copyright Clearance Center, Inc.

4. Adjustable Speed Drive. Torque or speed regulation is achieved via scalar or vector control (see "Variable Speed Drives" in previous chapter).

4.2.2 Equivalent Circuits and Characteristics

Induction machine equivalent circuit

The steady-state characteristics of induction machines with either a wound- or cage-type rotor may be determined via the equivalent circuit in the figure below.

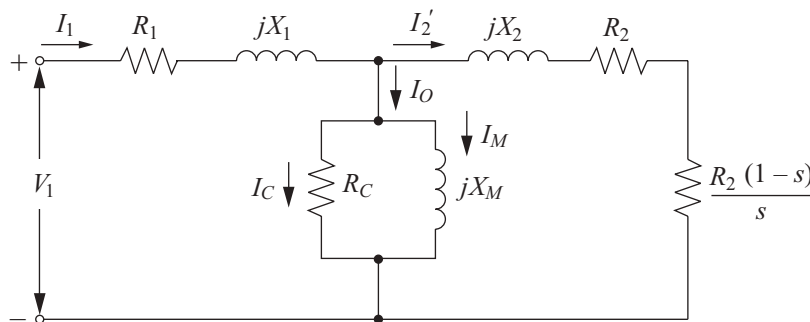

Republished with permission of McGraw-Hill, from Chapman, Stephen, *Electric Machines and Power System Fundamentals*, McGraw-Hill, 2001, p. 339; permission conveyed through Copyright Clearance Center, Inc.

By referring all circuit parameters to the stator winding, the equivalent circuit can be approximated by the following:

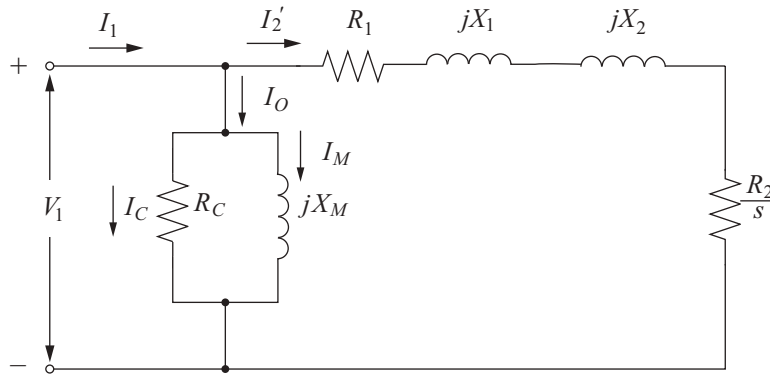

Wildi, Theodore, *Electrical Machines, Drives, and Power Systems*, 6 ed., Pearson, 2005, p. 333, fig. 15.6.

4.2.3 Motor Starting

Four starting methods are commonly used with induction machines:

1. **Across-the-Line Starting.** Full line voltage is applied to the stator winding with a starting circuit like that shown in the figure below. This method is applicable when the voltage dip during initial motor acceleration is within acceptable limits.

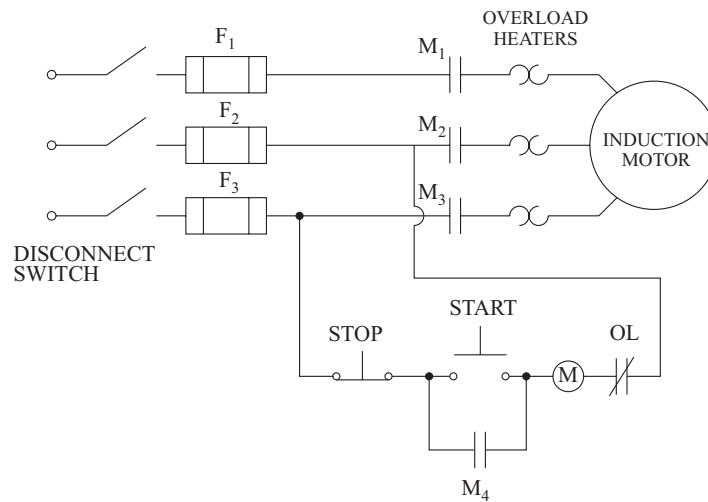

Republished with permission of McGraw-Hill, from Chapman, Stephen, *Electric Machines and Power System Fundamentals*, McGraw-Hill, 2001, p. 432; permission conveyed through Copyright Clearance Center, Inc.

2. **Rotor Resistance Starting.** A resistance bank is connected to the rotor terminals to limit the starting current. This is only possible for wound-rotor induction motors.

3. Reduced Voltage Starting. A 3-phase autotransformer can be used to provide reduced terminal voltage during the starting sequence as shown below.

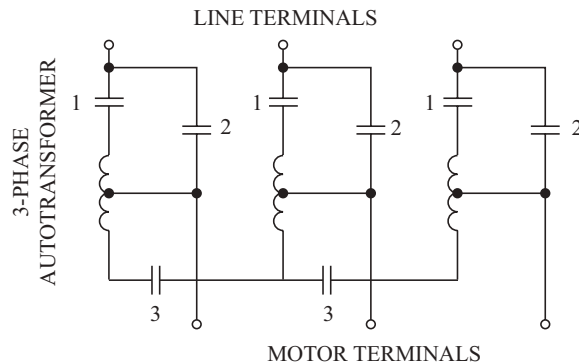

STARTING SEQUENCE:
 (A) CLOSE 1 AND 3
 (B) OPEN 1 AND 3
 (C) CLOSE 2

Republished with permission of McGraw-Hill, from Chapman, Stephen, *Electric Machines and Power System Fundamentals*, McGraw-Hill, 2001, p. 432; permission conveyed through Copyright Clearance Center, Inc.

4. Wye/Delta Starting. The motor is designed for normal operation with delta-connected stator windings. But during the starting sequence, the stator windings are switched to wye connections to reduce the line current until the motor approaches steady-state speed.

4.2.4 Electrical Machine Theory

Induction machine theory

The torque-speed characteristic of a 3-phase induction machine is shown below. Three different modes of operation are possible depending on whether the rotor speed is negative (braking), subsynchronous (motoring), or supersynchronous (generating).

The frequency and the voltage induced in the rotor depend on the motor slip and line frequency. The rotor frequency is given by $s \cdot f_{line}$, and the rotor voltage induced at slip s is $s \cdot E_{oc}$, where E_{oc} is the open-circuit voltage induced in the rotor when at rest.

A more detailed depiction of the torque-speed curve in the motoring region of operating for a particular induction machine is shown below.

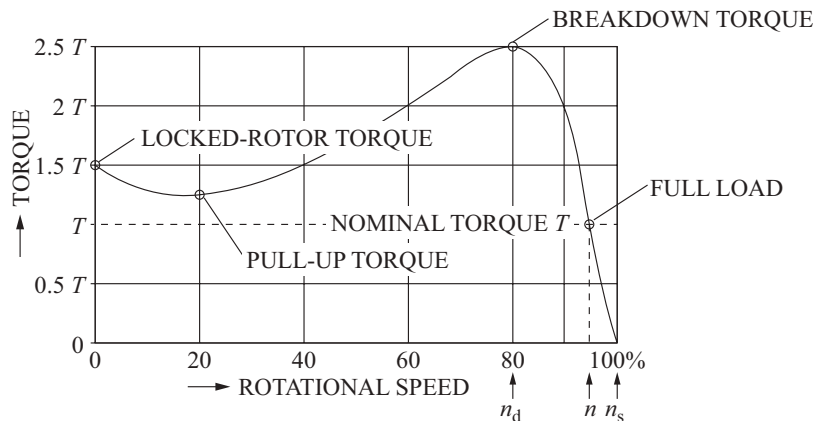

Wildi, Theodore, *Electrical Machines, Drives, and Power Systems*, 6 ed., Pearson, 2005, p. 282, fig. 13.17.

The torque-speed characteristic may be derived from the induction machine equivalent circuit, as follows:

For a 3-phase induction machine, the power transmitted to the rotor (air-gap power) P_r is:

$$P_r = 3I_2^2 \frac{R_2}{s}$$

The rotor copper losses are sP_r ; therefore, the gross mechanical output P_m is:

$$P_m = (1 - s) P_r$$

The gross mechanical torque T_m is:

$$T_m = \frac{P_m}{(1 - s)\omega_s} = \frac{P_r}{4\pi f}$$

The net shaft power and torque will be slightly lower than the gross amounts due to friction and windage losses.

An approximation of the steady-state electromagnetic torque, T_e (N•m), for a 3-phase induction machine expressed as a function of the equivalent circuit parameters is:

$$T_e = \frac{3}{\omega_s} \cdot \frac{E^2 (R_2/s)}{(R_1 + R_2/s)^2 + (X_1 + X_2)^2}$$

where ω_s is the machine's synchronous speed in radians per second and the stator parameters have been reflected to the rotor winding. This approximation assumes that $Z_M \gg Z_1$.

The condition for maximum torque is given by:

$$\frac{R_2}{s_{\max T}} = \sqrt{R_1^2 + (X_1 + X_2)^2}$$

where $s_{\max T}$ is the slip at which the maximum torque (breakdown torque) will occur.

4.2.5 3-Phase Induction Motor Power Flow

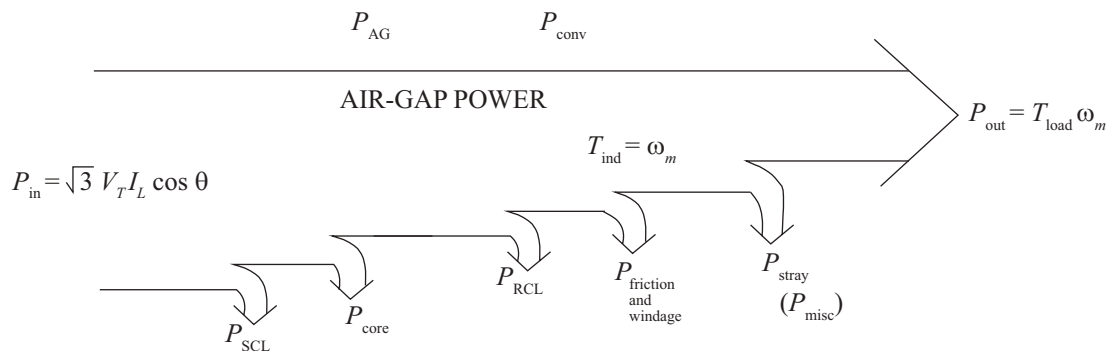

Republished with permission of McGraw-Hill, from Chapman, Stephen, *Electric Machines and Power System Fundamentals*, McGraw-Hill, 2001, p. 394; permission conveyed through Copyright Clearance Center, Inc.

where

V_T = supply line voltage (line voltage applied to the stator)

I_L = stator line current

ω_m = rotor speed

4.3 Electric Power Devices

4.3.1 Transformers

4.3.1.1 Single-Phase Transformer Equivalent Circuits

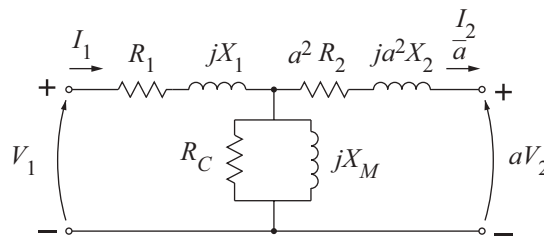
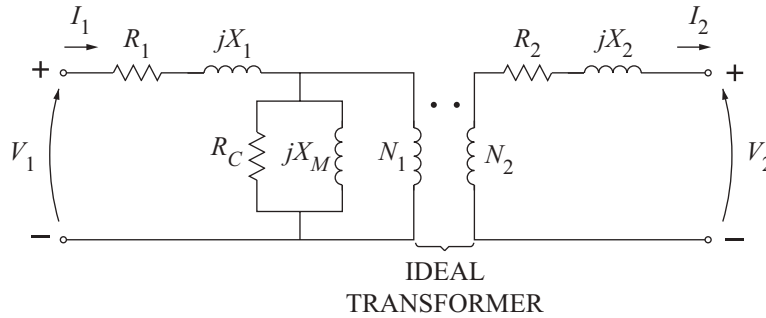

Transformer's exact equivalent circuit

Republished with permission of McGraw-Hill, from Chapman, Stephen, *Electric Machines and Power System Fundamentals*, McGraw-Hill, 2001, p. 88; permission conveyed through Copyright Clearance Center, Inc.

The emf induced in the primary winding

$$E_1 = 4.44N_1 f \phi_{\max}$$

The emf induced in the secondary winding

$$E_2 = 4.44N_2 f \phi_{\max}$$

Turns ratio (transformation ratio)

$$a = \frac{N_1}{N_2}$$

In an ideal transformer

$$\frac{E_1}{E_2} = \frac{I_2}{I_1} = \frac{N_1}{N_2} = a$$

Transformer's approximate equivalent circuit is shown below.

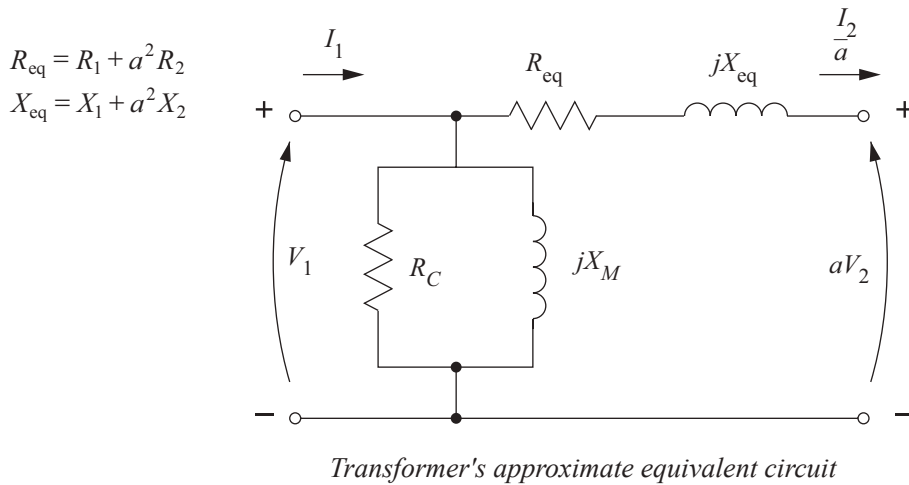

Republished with permission of McGraw-Hill, from Chapman, Stephen, *Electric Machines and Power System Fundamentals*, McGraw-Hill, 2001, p. 89; permission conveyed through Copyright Clearance Center, Inc.

R_1, R_2, X_1, X_2 are the resistance and leakage reactance of the transformer's primary and secondary windings, respectively.

R_o, X_o are the core-loss equivalent resistance and magnetizing reactance, respectively.

The secondary voltage referred to the primary $V_2' = aV_2$

The secondary winding current referred to the primary $I_2' = \frac{I_2}{a}$

The secondary winding resistance referred to the primary $R_2' = a^2 R_2$.

The secondary winding leakage reactance referred to the primary $X_2' = a^2 X_2$

The secondary winding impedance referred to the primary $Z_2' = R_2' + jX_2'$
 $Z_2' = a^2 Z_2$

The transformer's output power (power fed to the load) $P_{out} = P_2 = V_2' I_2' \cos \theta_2$

The load power factor = $\cos \theta_2$

The transformer's input (primary) power $P_{inp} = P_1 = V_1 I_1 \cos \theta_1$

The input (primary) power factor = $\cos \theta_1$

4.3.1.2 Transformer Losses

Primary winding copper losses $I_1^2 R_1$

Secondary winding copper losses $I_2^2 R_2 = I_2'^2 R_2'$

Transformer's total copper losses $I_1^2 R_1 + I_2^2 R_2$

Transformer core (eddy + hysteresis) losses $P_c = P_{e+h} = P_e + P_h$

Eddy current losses $P_e = K_e f^2 B_m^2$

Hysteresis losses $P_h = K_h f B_m^n, n = 1.5 \rightarrow 2.5$

4.3.1.3 Transformer's Percentage Voltage Regulation

$$\%VR = \frac{|V'_{2-nl}| - |V'_{2-fl}|}{|V'_{2-fl}|} \times 100$$

The transformer %VR at rated voltage is given by:

$$\%VR = \frac{I_{op}}{I_{ra}} \left\{ \%R \cos(\theta) + \%X \sin(\theta) + \left[\%X \cos(\theta) - \%R \sin(\theta) \right]^2 / 200 \right\}$$

where

%R = transformer's percentage resistance

%X = percentage leakage reactance

I_{op} = transformer operating current

I_{ra} = transformer rated current

θ = power factor angle

4.3.1.4 Transformer's Efficiency

$$\eta = \frac{P_{out}}{P_{out} + (P_{cu} + P_c)} \times 100\%$$

4.3.1.5 Condition for Maximum Efficiency

The condition for maximum efficiency (based on the transformer's approximate equivalent circuit) is that maximum

$$P_{cu} = P_{core}$$

The percentage load at the highest efficiency is given by:

$$\%load = \sqrt{\frac{P_{core}}{P_{cu}}} \times 100$$

where

P_{cu} = transformer copper losses (winding losses)

P_{core} = transformer iron losses (core losses)

4.3.1.6 Single-Phase Transformers in Parallel

The conditions for two single-phase transformers to be connected in parallel:

1. The transformers have the same transformation ratio.
2. The transformers have identical voltage ratings.
3. The transformers have identical frequency ratings.
4. The transformers have identical tap settings.
5. The transformers are connected to the same primary phase.

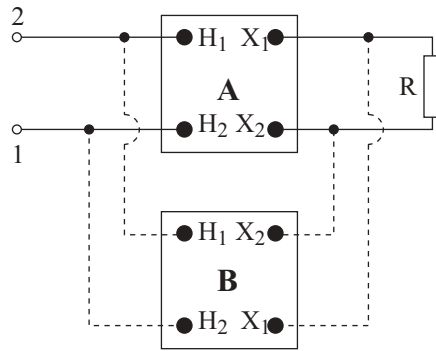

Single-phase transformers in parallel

Wildi, Theodore, *Electrical Machines, Drives, and Power Systems*, 6 ed., Pearson, 2005, p. 219, fig. 10.34.

$$\frac{I_1}{I_2} = \frac{(\%Z_{T_2})S_{T_1}}{(\%Z_{T_1})S_{T_2}}$$

$$\frac{S_{L_1}}{S_{L_2}} = \frac{(\%Z_{T_2})S_{T_1}}{(\%Z_{T_1})S_{T_2}}$$

where

I_1 = current supplied to the load by Transformer 1

I_2 = current supplied to the load by Transformer 2

S_{L_1} = kVA supplied to the load by Transformer 1

S_{L_2} = kVA supplied to the load by Transformer 2

$\%Z_{T_1}$ = % leakage impedance of Transformer 1

$\%Z_{T_2}$ = % leakage impedance of Transformer 2

S_{T_1} = kVA rating of Transformer 1

S_{T_2} = kVA rating of Transformer 2

4.3.1.7 Autotransformers

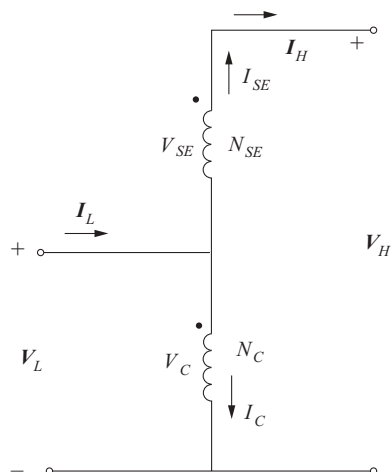

Republished with permission of McGraw-Hill, from Chapman, Stephen, *Electric Machines and Power System Fundamentals*, McGraw-Hill, 2001, p. 110; permission conveyed through Copyright Clearance Center, Inc.

The voltage and current relationships are given as:

$$\frac{V_L}{V_H} = \frac{N_C}{N_{SE} + N_C}$$

$$\frac{I_L}{I_H} = \frac{N_{SE} + N_C}{N_C}$$

The ratio of the input and output apparent power (S_{IO}) to the apparent power traveling through the windings (S_W) is given as:

$$\frac{S_{IO}}{S_W} = \frac{N_{SE} + N_C}{N_{SE}}$$

4.3.2 Reactors

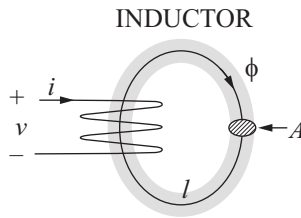

The inductance L (henrys) of a coil of N turns wound on a core with cross-sectional area A (m^2), permeability μ and flux ϕ with a mean path of l (m) is given as:

$$L = N^2 \mu A / l = N^2 / \mathfrak{R}$$

$$N\phi = Li$$

where \mathfrak{R} = reluctance = $l/\mu A$ (H^{-1}).

μ is sometimes given as $\mu = \mu_r \cdot \mu_o$ where μ_r is the relative permeability and $\mu_o = 4\pi \times 10^{-7}$ H/m.

Using Faraday's law, the voltage-current relations for an inductor are

$$v_L(t) = L (di_L / dt)$$

$$i_L(t) = i_L(0) + \frac{1}{L} \int_0^t v_L(\tau) d\tau$$

where

v_L = inductor voltage

L = inductance (henrys)

i_L = inductor current (amperes)

The energy stored in an inductor is expressed in joules and given by

$$\text{Energy} = Li_L^2 / 2$$

The relationship between inductance and reactive power is:

$$L_{ph} = \frac{V_{ph}^2}{(2\pi f)(\text{MVAR/phase})}$$

where

L_{ph} = inductance (H) per phase

V_{ph} = phase voltage (kV)

f = frequency (Hz)

4.3.3 Testing

Two common tests applied to transformers are the open-circuit and short-circuit tests.

4.3.3.1 Open-Circuit Testing

If $V_o = V_{ra}$ is the rated voltage applied, I_o is the no-load current measured during the test, and P_o is the no-load power (core losses), then:

$$P_{\text{core}} = P_o$$

$\cos(\theta_o) = \frac{P_o}{V_o I_o}$ is the no-load power factor

$$I_c = I_o \cos(\theta_o)$$

$$I_m = I_o \sin(\theta_o)$$

where

I_c = core loss current

I_m = core magnetizing current

The core equivalent circuit parameters R_c and X_m are given by:

$$R_c = \frac{V_o}{I_c}$$

$$X_m = \frac{V_o}{I_m}$$

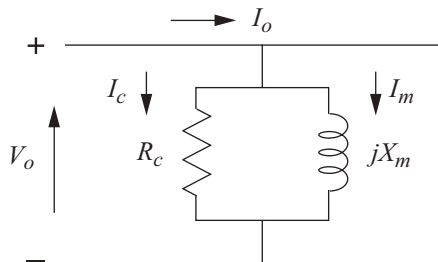

Single-phase transformer
No-load equivalent circuit

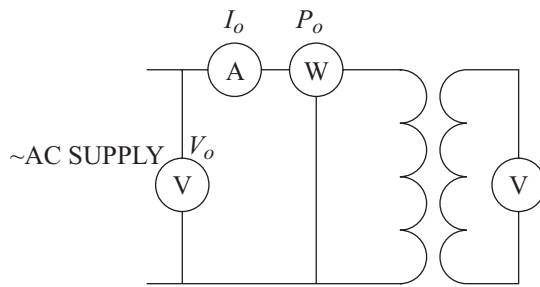

No-load test connection

Reprinted from *Electrical Machines and their Applications*, 2 ed., John Hindmarsh, p. 195, © 1970, with permission from Elsevier.

Guru, Bhag S., and Huseyin Hiziroglu, *Electric Machinery and Transformers*, 3 ed., Oxford University Press, 2001, p. 233.

4.3.3.2 Short-Circuit Test

If V_{sc} is the reduced voltage applied, $I_{sc} = I_{ra}$ is the short-circuit current measured during the test, and P_{sc} is the power measured (copper losses), then:

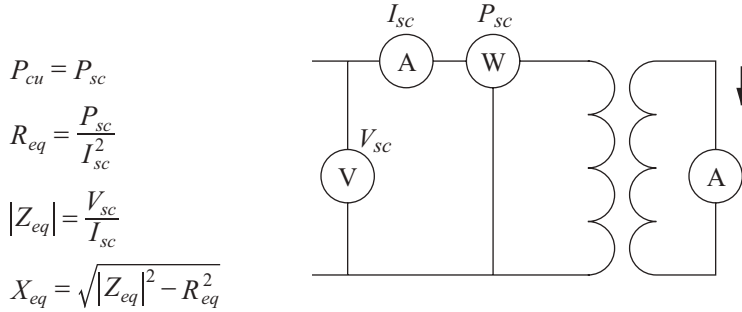

Short-circuit test connection

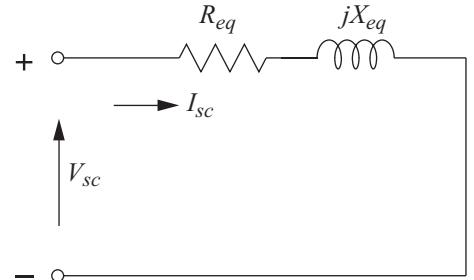

Single-phase transformer approximate equivalent circuit under short-circuit test

$$P_{cu} = P_{sc}$$

$$R_{eq} = \frac{P_{sc}}{I_{sc}^2}$$

$$|Z_{eq}| = \frac{V_{sc}}{I_{sc}}$$

$$X_{eq} = \sqrt{|Z_{eq}|^2 - R_{eq}^2}$$

Reprinted from *Electrical Machines and their Applications*, 2 ed., John Hindmarsh, p. 198, © 1970, with permission from Elsevier.

4.3.4 Capacitors

The charge $q_C(t)$ and voltage $v_C(t)$ relationship for a capacitor C in farads is

$$C = q_C(t)/v_C(t) \quad \text{or} \quad q_C(t) = Cv_C(t)$$

A parallel plate capacitor of area A with plates separated a distance d by an insulator with a permittivity ϵ has a capacitance

$$C = \frac{\epsilon A}{d}$$

ϵ is often given as $\epsilon = \epsilon_r (\epsilon_0)$ where ϵ_r is the relative permittivity or dielectric constant and $\epsilon_0 = 8.85 \times 10^{-12}$ F/m.

The current-voltage relationships for a capacitor are

$$v_C(t) = v_C(0) + \frac{1}{C} \int_0^t i_C(\tau) d\tau \quad \text{and}$$

$$i_C(t) = C (dv_C/dt)$$

The energy stored in a capacitor is expressed in joules and given by

$$\text{Energy} = Cv_C^2/2 = q_C^2/2C = q_C v_C/2$$

The relationship between capacitance and reactive power is:

$$C_{ph} = \frac{\text{MVAR/phase}}{2\pi f V_{ph}^2}$$

where

C_{ph} = capacitance (F) per phase

V_{ph} = phase voltage (kV)

5 TRANSMISSION AND DISTRIBUTION

5.1 Power System Analysis

5.1.1 Voltage Drop

In a two-wire ac or dc circuit, balanced three-wire single-phase ac circuit, or balanced 3-phase ac circuit, when the constant load current is at unity power factor and the conductor reactance is negligible, voltage drop is:

$$VD = \frac{2 \cdot L \cdot R \cdot I}{K \cdot 1,000}$$

where

VD = voltage drop between conductors (V)

L = one-way length of circuit (ft)

R = conductor resistance (Ω per 1,000 ft)

I = load current (A)

K = 1.0 for single-phase ac or dc circuit

K = $2/\sqrt{3}$ for 3-phase ac circuit

When circuit reactance is not negligible and/or the load power factor is not unity, the line-to-neutral voltage drop in a 3-phase ac circuit for a balanced constant-current load may be approximated by:

$$VD_{ln} \approx I \cdot [R \cdot PF + X \cdot \sin(\cos^{-1}(PF))]$$

where

VD_{ln} = line-to-neutral voltage drop (V)

I = load current (A)

R = per-phase conductor resistance (Ω)

X = per-phase conductor reactance (Ω)

PF = power factor (pu)

5.1.2 Voltage Regulation

$$\% \text{Voltage Regulation} = \frac{V_{NL} - V_{FL}}{V_{FL}} \cdot 100\%$$

where

V_{NL} = voltage under no-load conditions

V_{FL} = voltage under full-load conditions

5.1.3 Power Factor Correction and Voltage Support

The required change in reactive power to change the power angle from Φ_1 to Φ_2 is:

$$\Delta P_{\text{reactive}} = P_{\text{real}}(\tan \Phi_1 - \tan \Phi_2)$$

The capacitance (in farads) required to change the reactive power by the above amount is given below.

V_{line} is the (rms) voltage:

$$C = \Delta P_{\text{reactive}} / (2\pi f V_{\text{line}}^2)$$

Power factor loss reduction:

$$\% \text{ Loss Reduction} = 100[1 - (PF_1/PF_2)^2]$$

PF_1 = original PF_2 = corrected

5.1.4 Power Quality

According to NEMA Standard MG-1, the percent voltage unbalance of a 3-phase supply is based on the average of the three phase-to-phase voltages and the maximum deviation with respect to that average phase-to-phase voltage as follows:

$$\text{Voltage Unbalance (\%)} = \frac{\text{Maximum Voltage Deviation}}{\text{Average Voltage}} \cdot 100\%$$

The percent total harmonic distortion (THD) of a periodic signal is:

$$\text{THD (\%)} = \frac{\sqrt{\sum_{n=2}^{\infty} V_n^2}}{V_1} \cdot 100\%$$

where

V_n = RMS amplitude of the n th harmonic frequency of signal V

V_1 = RMS amplitude of the fundamental frequency of signal V

The resonant frequency ω_r of an RLC circuit in rad/s is $\frac{1}{\sqrt{LC}}$.

In a series resonant circuit, the quality factor Q is $\frac{\omega_r L}{R} = \frac{1}{\omega_r RC}$.

In a parallel resonant circuit, Q is $\frac{R}{\omega_r L} = \omega_r RC$.

For both series and parallel resonant RLC circuits, the bandwidth F_B is $\frac{\omega_r}{Q}$.

5.1.5 Fault Current Analysis

Fault duties may be expressed in terms of current (kA) or apparent power at nominal voltage (MVA). The short-circuit MVA for a balanced 3-phase fault is:

$$S_{\text{sc}} = \sqrt{3} \cdot V_{\text{nom}} \cdot I_{\text{sc}}$$

where

S_{sc} = short-circuit duty (MVA)

V_{nom} = nominal line voltage (kV)

I_{sc} = short-circuit current (kA)

Balanced and unbalanced fault currents may be analyzed by constructing the positive-, negative- and zero-sequence networks for the system under consideration, then interconnecting the sequence networks to solve for the symmetrical components of current and voltage. The diagram below indicates the use of these network connections for common fault types.

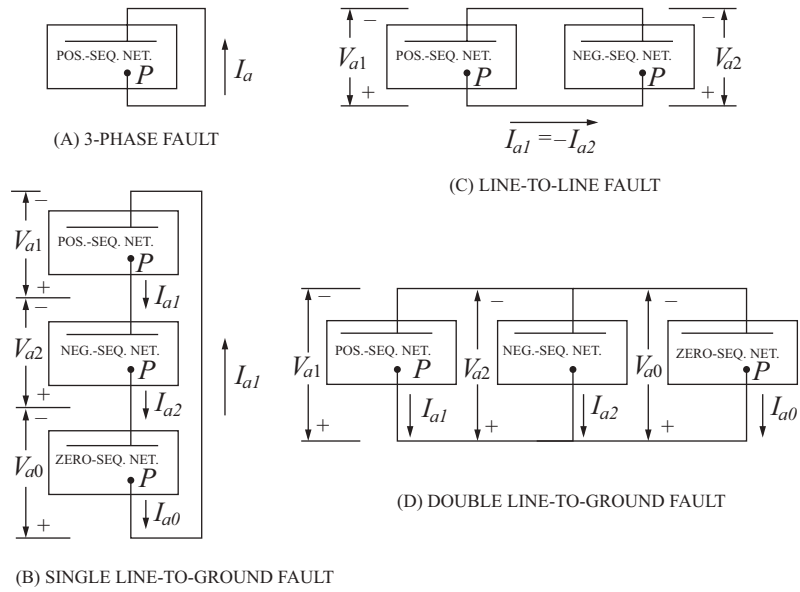

Republished with permission of McGraw-Hill, from Stevenson, W.D., Jr., *Elements of Power System Analysis*, 4 ed., 1982; permission conveyed through Copyright Clearance Center, Inc.

Chapter 5: Transmission and Distribution

For faults not involving ground, the effect of fault impedance Z_F can be included by placing Z_F in series with the connection to the fault location in the positive-sequence network. For faults involving ground, an impedance of $3Z_F$ is placed in series with the connection to the fault location in the zero-sequence network to account for the in-phase summation of the three zero-sequence currents.

The zero-sequence model for wye-connected loads and generators depends on the nature of the connection between the star point and ground. The diagram below depicts the zero-sequence networks for ungrounded, solidly grounded, and impedance grounded wye-connected loads, respectively.

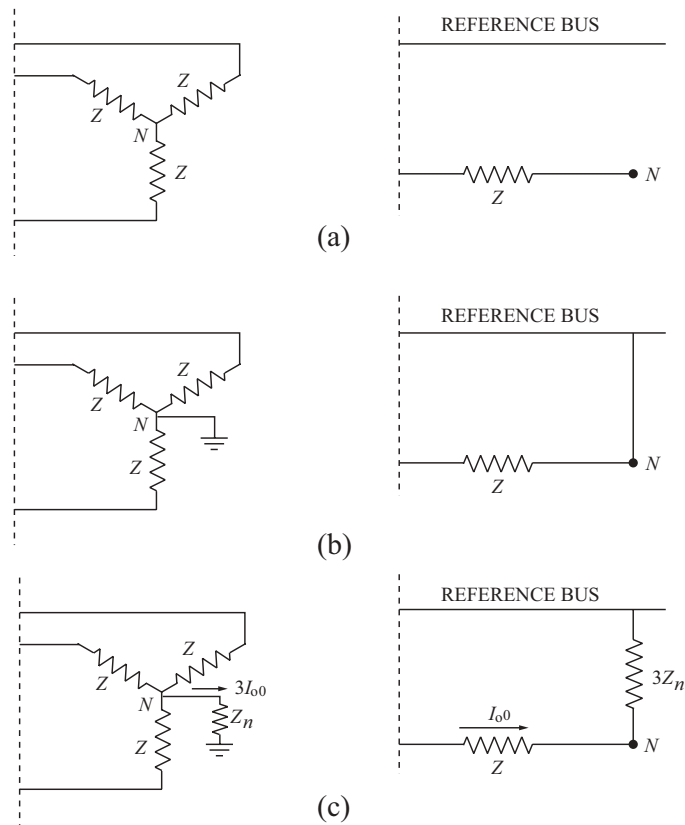

Republished with permission of McGraw-Hill, from Stevenson, W.D., Jr., *Elements of Power System Analysis*, 4 ed., 1982; permission conveyed through Copyright Clearance Center, Inc.

Chapter 5: Transmission and Distribution

Likewise, the zero-sequence model for 3-phase transformer banks is dependent on the nature of the connection between the star point of any wye-connected windings and ground. The diagram below depicts the zero-sequence network models for common transformer winding connections.

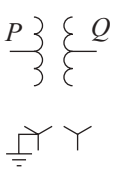
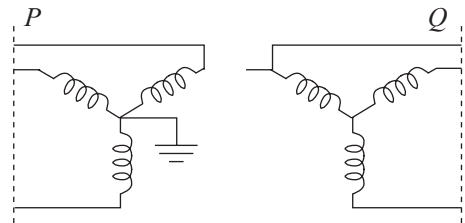
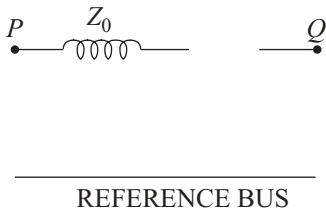
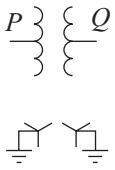
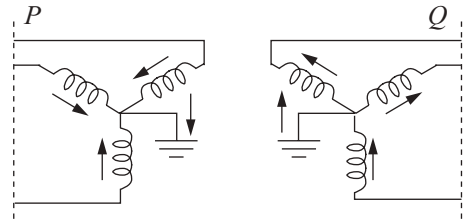
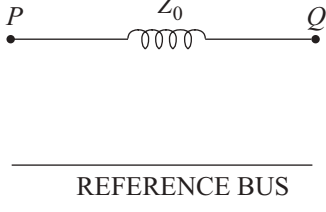
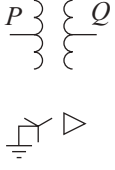
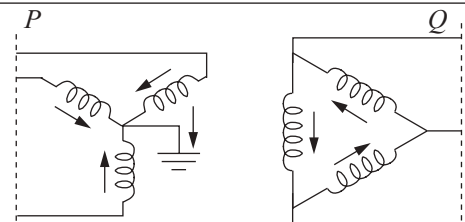
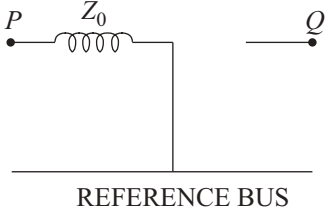
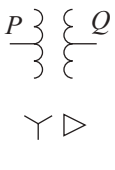
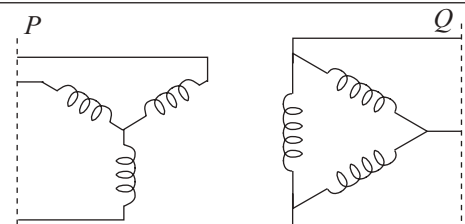
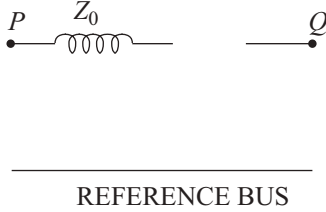
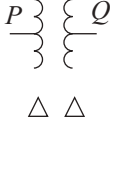
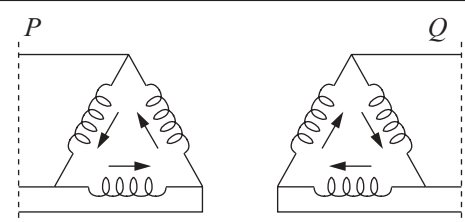
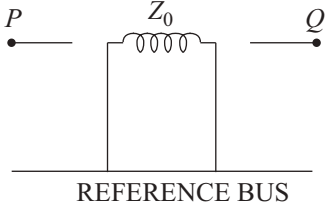
SYMBOLS	CONNECTION DIAGRAMS	ZERO-SEQUENCE EQUIVALENT CIRCUITS
		
		
		
		
		

Republished with permission of McGraw-Hill, from Stevenson, W.D., Jr., *Elements of Power System Analysis*, 4 ed., 1982; permission conveyed through Copyright Clearance Center, Inc.

5.1.6 Transmission Line Models

A general model of a power transmission line between the sending and receiving ends is shown below.

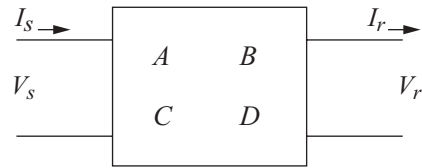

where A , B , C , and D are the transmission line constants, V_s and I_s are the sending-end phase voltage and current, and V_r and I_r are the receiving-end phase voltage and current. Based on the line length and the level of accuracy required, distributed parameters and lumped-circuit models of power transmission lines can be developed.

If $z = r + jx$ is the line impedance in Ω per-phase per-unit length, and y is the line admittance in Ω^{-1} per-phase per-unit length, then:

$$Z = z \cdot \text{length} = R + jX_L = \text{equivalent total impedance of the line } (\Omega)$$

$$Y_c = y \cdot \text{length} = \text{equivalent total admittance of the line } (\Omega^{-1})$$

$$\gamma = \sqrt{zy} = \text{line propagation constant}$$

$$\gamma = \alpha + j\beta$$

$$Z_c = \sqrt{\frac{z}{y}} = \text{line characteristic impedance } (\Omega)$$

Z_s is the line surge impedance, and is equal to the characteristic impedance for a lossless line (all losses ignored).

The line general equations between the sending and receiving ends:

$$V_s = A \cdot V_r + B \cdot I_r$$

$$I_s = C \cdot V_r + D \cdot I_r$$

The transmission efficiency of the line is given by:

$$\eta = \frac{P_r}{P_s} \times 100$$

The line percentage voltage regulation is given by:

$$\%VR = \frac{|V_{r_{nl}}| - |V_{r_{fl}}|}{|V_{r_{fl}}|} \times 100$$

$$\%VR = \frac{|V_s/A| - |V_{r_{fl}}|}{|V_{r_{fl}}|} \times 100$$

where $V_{r_{nl}}$ and $V_{r_{fl}}$ are the line receiving-end no-load and full-load voltages, respectively.

The approximate line power transfer is:

$$P \cong \frac{V_s V_r}{X_L} \sin(\delta)$$

The line maximum power transfer is:

$$P \cong \frac{V_s V_r}{X_L}$$

The surge impedance loading SIL in MW is given by:

$$SIL = \frac{V_{\text{line}}^2}{Z_s}$$

where

V_{line} = line rated line voltage (kV)

Z_s = line surge impedance

5.1.6.1 Short Transmission Line Model

For line length $l \leq 50$ miles, a 60-Hz transmission line may be represented by the lumped parameter model shown in the figure below.

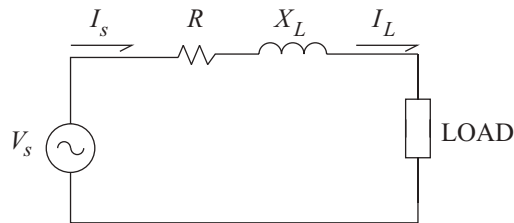

Grainger, J. and William Stephenson, *Power System Analysis*, McGraw-Hill, 1994, p. 196.

Neglecting the line admittance, the line constants are given by:

$$A = D = 1$$

$$B = Z$$

$$C = 0$$

5.1.6.2 Medium Transmission Line Model

For line length $l > 50$ miles and ≤ 150 miles, a 60-Hz transmission line may be represented by the lumped parameter model shown in the figure below.

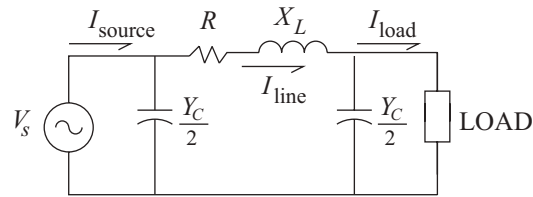

Grainger, J. and William Stephenson, *Power System Analysis*, McGraw-Hill, 1994, p.201.

$$A = 1 + ZY/2$$

$$B = Z$$

$$C = (1 + ZY/4)Y$$

$$D = A$$

5.1.6.3 Long Transmission Line Model

For line length $l > 150$ miles, a 60-Hz transmission line is normally represented by the distributed parameter model shown in the figure below.

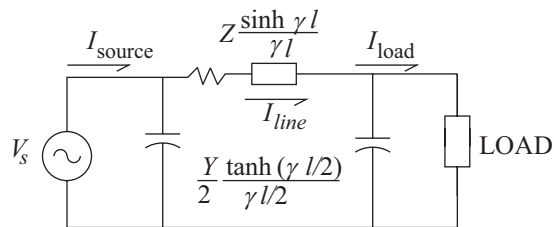

Grainger, J. and William Stephenson, *Power System Analysis*, McGraw-Hill, 1994, p. 214.

$$A = \cosh(\gamma l)$$

$$B = Z_c \sinh(\gamma l)$$

$$C = \frac{\sinh(\gamma l)}{Z_c}$$

$$D = A$$

5.1.7 Transmission Line Parameters

Lumped transmission line model parameters are influenced by the conductor type, temperature, phase, and bundle configuration. The phase configuration is defined by the centerline spacing of each phase conductor as shown in the figure below.

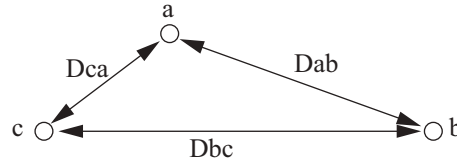

At line voltages ≥ 230 kV, it is common that each phase conductor be composed of a bundle of two, three, or four conductor sub-conductors to reduce corona losses. Typical bundle configurations are shown below.

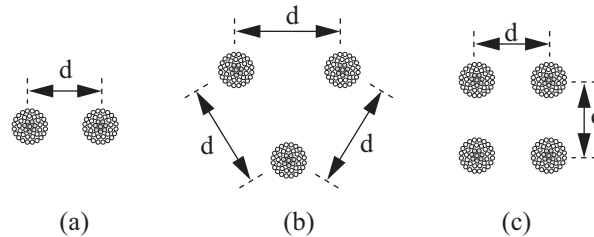

Grainger, J. and William Stephenson, *Power System Analysis*, McGraw-Hill, 1994, p. 214.

The conductor dc resistance R_{dc} is given by:

$$R_{dc} = \frac{\rho l}{A}$$

Accounting for skin effect, the conductor ac resistance R_{ac} is given by:

$$R_{ac} = kR_{dc}$$

$$k > 1$$

The line resistance can be obtained at a different temperature using the following equation:

$$\frac{R_2}{R_1} = \frac{M + T_2}{M + T_1}$$

where M is the line's temperature constant and the temperatures T_1 and T_2 in degree Celsius. $M = 228.1$ for aluminum.

5.1.8 Line Inductance and Inductive Reactance

The average line inductance is:

$$L = \frac{\mu_o}{2\pi} \ln\left(\frac{D_{eq}}{GMR}\right) \text{ (H/m)}$$

The line's average inductive reactance is given by:

$$X_L = 2.022 \times 10^{-3} f \ln\left(\frac{D_{eq}}{GMR}\right) \text{ (\Omega/mi)}$$

The average capacitance to neutral is given by:

$$C = \frac{2\pi\epsilon_o}{\ln\left(\frac{D_{eq}}{GMR_c}\right)} \text{ (F/m)}$$

The average capacitive reactance to neutral is:

$$X_c = \frac{1.779}{f} \times 10^6 \ln \frac{D_{eq}}{GMR_c} \quad (\Omega \cdot \text{mi})$$

where

f = line frequency (Hz)

D_{eq} = equivalent equilateral spacing of a fully transposed 3-phase line = $\sqrt[3]{D_{ab}D_{bc}D_{ca}}$

$r' = 0.7788r$ = geometric mean radius of a subconductor with radius r

GMR (the geometric mean radius of a bundled conductor) is given by:

$GMR = \sqrt{r'd}$ for the two-subconductor bundle

$GMR = \sqrt[3]{r'(d)(d)}$ for three-subconductor bundle with equilateral subconductor spacing

$GMR = \sqrt[4]{r'(d)(d)(\sqrt{2}d)}$ for a four-subconductor bundle in a square configuration

GMR_c is calculated the same way as GMR with the virtual radius r' replaced with the subconductor's radius r .

5.1.9 Power Flow

The power flow between two balanced 3-phase voltage sources E_1 and E_2 can be given by:

$$P = 3 \frac{E_1 E_2}{X} \sin(\delta)$$

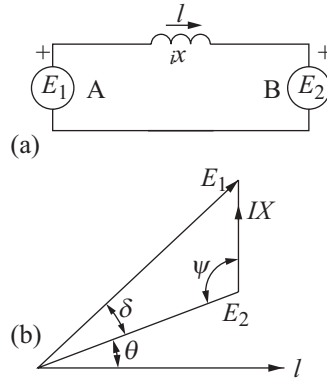

An important input to a power flow solution for a network is the bus admittance matrix Y_{bus} , which relates the bus voltages to the bus currents in a network as follows:

$$I = Y_{bus} V$$

where I and V are vectors representing the net current flowing into the bus and the bus voltage, respectively, for each bus in the network.

The elements of Y_{bus} may be determined per the following equations, which are derived by applying Kirchhoff's Current Law at every bus in the network:

$$Y_{ij} = \begin{cases} y_i + \sum_{k=1, k \neq i}^N y_{ik}, & \text{for } i = j \\ -y_{ij}, & \text{for } i \neq j \end{cases}$$

where

y_i = net admittance from bus i to reference bus

y_{ik} = net admittance from bus i to bus k

y_{ij} = net admittance from bus i to bus j

N = number of buses in network

5.1.10 Power System Stability

The mechanical dynamics of the rotor of a synchronous machine when subjected to an electromechanical disturbance are described by the following differential equation (known as the "Swing Equation"):

$$J \frac{d^2 \theta_m}{dt^2} = T_a = T_m - T_e$$

where

J = moment of inertia of rotor mass ($\text{kg}\cdot\text{m}^2$)

θ_m = angular displacement of rotor mass (mechanical radians)

T_m = mechanical torque applied to rotor shaft ($\text{N}\cdot\text{m}$)

T_e = electromagnetic torque developed by generator ($\text{N}\cdot\text{m}$)

T_a = net accelerating torque ($\text{N}\cdot\text{m}$)

An alternative formulation of the swing equation utilizing per-unit quantities is:

$$\frac{2H}{\omega_s} \frac{d^2 \delta}{dt^2} = P_a = P_m - P_e$$

where

H = machine H constant (per unit, defined below)

δ = rotor angle (electrical radians)

ω_s = rotor synchronous speed = $2\pi f$ (electrical rad/s)

P_m = mechanical power applied to rotor shaft (per unit)

P_e = electromagnetic power developed by generator (per unit)

P_a = net accelerating power (per unit)

The machine H constant is defined as:

$$H = \frac{\text{Stored Kinetic Energy at Synchronous Speed (MJ)}}{\text{Machine Rating (MVA)}}$$

$$= \frac{\frac{1}{2} J \omega_{sm}^2}{S_{mach}}$$

where

ω_{sm} = rotor speed (mechanical rad/s)

S_{mach} = base MVA for machine

The power-angle equation relates the electromagnetic power developed by the generator to the electrical rotor angle as follows:

$$P(\delta) = \frac{|E||V_t|}{X} \sin \delta$$

where

P = generator electrical power output (per unit)

δ = electrical rotor angle (degrees or radians)

E = generator emf (per unit)

V_t = generator terminal voltage (pu)

X = generator reactance (pu)

For evaluation of steady-state stability, X is the direct-axis synchronous reactance X_d . For transient stability analysis, X is the direct-axis transient reactance X_d' .

A common output from a transient stability analysis is the rotor angle and maximum time needed to clear a 3-phase fault at the terminals of a synchronous generator to prevent instability. If the generator is small relative to the connected system, the system can be considered an infinite bus, and the so-called Equal Area Criterion applied to the analysis. This criterion is based on the power-angle equation, the swing equation, and the principle that whatever kinetic energy is added to the rotor during the fault must be removed after fault clearance in order for the rotor to return to synchronous speed. This is shown graphically in the figure below.

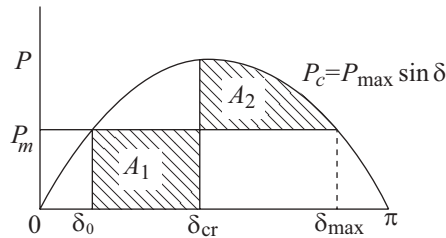

The critical clearing angle δ_{cr} (electrical radians) and time t_{cr} (seconds) are as follows:

$$\delta_{cr} = \cos^{-1} \left[(\pi - 2\delta_0) \sin \delta_0 - \cos \delta_0 \right]$$

$$t_{cr} = \sqrt{\frac{4H(\delta_{cr} - \delta_0)}{\omega_s P_m}}$$

where

δ_0 = steady-state electrical rotor angle prior to application of the fault